

SERVICE MANUAL

TEAC Tascam Series

22-4

4-Channel Multitrack Recorder/Reproducer

TEAC CORPORATION

5704 007200

TABLE OF CONTENTS

MAIN SECTION		
1	Introduction	3
2	Specifications	4
3	Parts location	6
4	Removal of external components	7
5	Maintenance	8
5-1	Test equipment	8
5-1-1	Standard equipment	8
5-1-2	Test tapes	8
5-2	Mechanical adjustments and checks	9
5-2-1	Capstan thrust clearance	9
5-2-2	Shut-off switch position	9
5-2-3	Brake mechanism	9
5-2-4	Brake torque	10
5-2-5	Reel motor torque	10
5-2-6	Pinch roller pressure	11
5-2-7	Reel table height	11
5-2-8	Tape speed	12
5-2-9	Wow and flutter (playback)	12
5-2-10	Head and tape path alignment	12
5-2-11	Voltage and frequency conversion	13
5-2-12	Lubrication	13
5-3	Electrical adjustments and checks	14
5-3-1	Precautions	14
5-3-2	Monitor performance	14
5-3-3	Playback performance	15
5-3-4	Recording performance	16
5-3-5	SIMUL-SYNC performance	19
5-4	Adjustment and test point locations	20
5-5	Level diagram	21
5-6	Block diagram	22

TABLE OF CONTENTS (Continued)

CIRCUIT DESCRIPTION SECTION		
6	Tape transport circuit description	24
6-1	System control IC	24
6-1-1	Terminal assignments and block diagram	24
6-1-2	Performances proper to respective inputs	25
6-1-3	Change of operating mode	25
6-1-4	Multiple input	26
6-1-5	Input/output levels	26
6-2	Initial reset circuit	27
6-3	Capstan motor circuit	27
6-4	Power muting circuit	28
6-4-1	Power on mute	28
6-4-2	Power off mute	28
6-5	Deck modes	29
6-5-1	Play mode	29
6-5-2	Rec/play mode	29
6-5-3	Pause mode	30
6-5-4	Fast mode	31
6-6	Reel motor driver circuit	32
6-6-1	Play mode	32
6-6-2	F.FWD mode	32
6-6-3	REW mode	32
6-7	Solenoid driver circuit	33
6-7-1	Capstan solenoid driver	33
6-7-2	Brake solenoid driver	33
6-7-3	Flashing circuit	33
6-8	LED driver circuit	34
6-8-1	Record LED	34
6-8-2	Pause LED	34
6-9	Memory circuit	35
7	Amplifier circuit description	36
7-1	Playback system	36
7-1-1	Play EQ amplifier	36
7-1-2	Play line amplifier	36
7-1-3	Output amplifier	36
7-2	Monitor system	36
7-2-1	Meter amplifier	36
7-2-2	PHONES amplifier	36
7-2-3	SYNC amplifier	36
7-3	Record system	36
7-3-1	Line amplifier	36
7-3-2	REC amplifier	37
7-3-3	Bias oscillator circuit	37
7-4	Signal control circuit	37
7-4-1	Audio signal circuit	37
7-4-2	Relay driver circuit	38

PARTS LIST SECTION

8	Exploded views and parts list	40
9	PC boards and parts list	49

1 INTRODUCTION

The TEAC Tascam Series 22-4 recorder/reproducer is a 4-track, 4-channel tape deck designed for professional-type recording set-ups, in which mixers, master recorders, microphones, auxiliary signal processors, and other equipment are used in conjunction as a complete recording system. The 22-4 features a 4-track, 4-channel format to allow recording flexibility and creativity, and via its special SIMUL-SYNC function, provides such professional recording capabilities as punch-in recording, overdubbing, ping-pong recording using a mixer, and the control and monitoring of individual tracks. Other special features such as selection of 15 ips and 7-1/2 ips with seven-inch reels, independent controls for individual track recording and/or monitoring, expanded-scale VU meters, manual cueing, three-motor, three-head design, variable pitch control, full remote-control capability, full IC logic control, built-in interface for optional dbx unit, and a memory-stop function provide complete professional-type multitrack recording capability in a cost-effective compact design.

Before beginning and after completing any checks or adjustments, make sure that the entire tape path has been properly cleaned and demagnetized. Even microscopic amounts of dust, dirt, and oxide build-up, as well as even a small degree of magnetization can degrade performance and invalidate any checks or adjustments. Always remember to turn the deck off before demagnetizing. If not, the signals produced by the degausser will register at extremely high VU levels, with the possibility that serious damage to the deck's circuitry and/or VU meters could be caused. Also remember never to turn the degausser on or off while in close proximity to the heads, as this may put a permanent charge on the heads, requiring them to be replaced.

- NOTES:**
1. In this manual, 0 dB is referenced to 1V.
 2. Parts marked with this sign (Δ) are critical to electrical safety. **ALWAYS** replace these with identical parts. Refer to the parts listing in this manual to ensure exact replacement.

2 SPECIFICATIONS

MECHANICAL

Tape	1/4", 1.0 mil, low noise, high output tape
Track Format	1/4 track, 4 channel, track width 0.036 inch (0.9 mm)
Reel Size	7 inch maximum per EIA/ANSI standard
Tape Speeds	15 and 7-1/2 inches per second, switchable
Speed Accuracy	15 ips $\pm 0.5\%$ deviation 7-1/2 ips $\pm 0.5\%$ deviation $\pm 6\%$
Pitch Control	15 ips ⁽¹⁾ $\pm 0.07\%$ peak (IEC/ANSI weighted) $\pm 0.10\%$ peak (IEC/ANSI unweighted)
Wow and Flutter	0.04% RMS (NAB weighted) 0.07% RMS (NAB unweighted)
	7-1/2 ips ⁽²⁾ $\pm 0.09\%$ peak (IEC/ANSI weighted) $\pm 0.12\%$ peak (IEC/ANSI unweighted) 0.05% RMS (NAB weighted) 0.08% RMS (NAB unweighted)
Fast Wind Time	120 seconds for 1,800 feet
Start Time	15 ips: less than 0.5 sec. to reach standard wow and flutter
Capstan Motor	FG (frequency generator) DC servo motor
Reel Motors	2-AC outer rotor induction motors
Head Configuration	3 heads; erase, record and reproduce
Dimension	See Fig. 2-1
Weight	40 pounds (18 kg), net

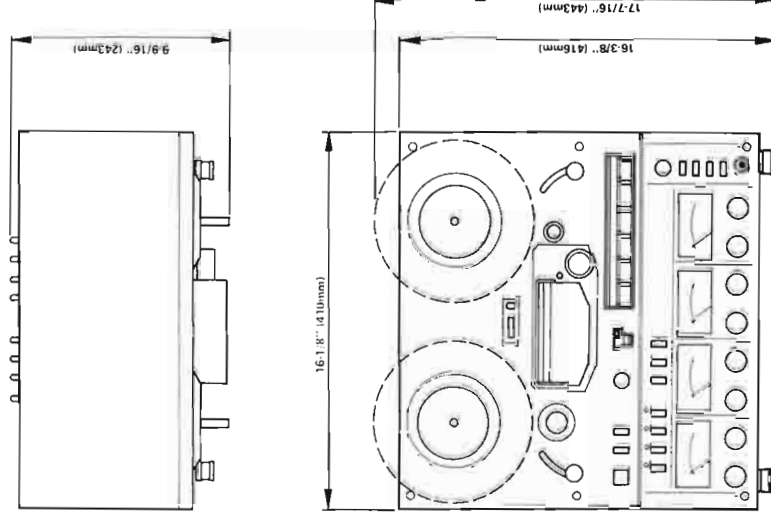

Fig. 2-1 Dimensions

ELECTRICAL

Line Input :	
Input impedance	50k ohms, unbalanced
Maximum source impedance	10k ohms or less
Nominal input level	-10 dBV (0.3V)
Minimum input level	-20 dBV (0.1V)
Line Output :	
Output impedance	1k ohms, unbalanced
Minimum load impedance	10k ohms or higher
Nominal output level	-10 dBV (0.3V)
Maximum output level	0 dBV (1 V)
Headphone Output	100mW maximum at 8 ohms, stereo headphones
Bias Frequency	100 kHz
Equalization	$\infty + 3.5\mu\text{sec. at } 15 \text{ ips}$ $3180\mu \text{ sec} + 50\mu \text{ sec at } 7\text{-}1/2 \text{ ips}$
Frequency Response ⁽³⁾ (Record/Reproduce)	15 ips 40 Hz-22 kHz, $\pm 3\text{dB}$ at 0 VU 35 Hz-25 kHz, $\pm 3\text{dB}$ at -10 VU 7-1/2 ips 40 Hz-16 kHz, $\pm 3\text{dB}$ at 0 VU 40 Hz-20 kHz, $\pm 3\text{dB}$ at -10 VU
Sync Response	15 ips 50 Hz-8 kHz, $\pm 3\text{dB}$ 7-1/2 ips 40 Hz-6.3 kHz, $\pm 3\text{dB}$
Total Harmonic Distortion (THD)	1.0% at 0 VU, 1,000 Hz, 185 nWb/m 3.0% at 10dB above 0 VU, 1,000 Hz, 585 nWb/m
Signal to Noise Ratio ⁽³⁾	At a reference of 1 kHz, at 10 dB above 0 VU, 585 nWb/m 15 ips 61 dB A weighted (NAB) 56 dB unweighted 88 dB A weighted (NAB), with dbx 78 dB unweighted, with dbx 7-1/2 ips 60 dB A weighted (NAB) 55 dB unweighted 88 dB A weighted (NAB), with dbx 78 dB unweighted, with dbx
Adjacent Channel Separation	Better than 40dB down at 1,000 Hz
Erase	Better than 70dB at 1,000 Hz, + 10 VU reference
Headroom	Recording Amplifier—Better than 23dB above 0 VU Playback Amplifier—Better than 23dB above 0 VU
Power requirements	100/117/220/240 V AC, 50/60 Hz, 70 W (General Export Model) 117 V AC, 60 Hz, 70 W (USA/Canada Model) 220 V AC, 50 Hz, 70 W (Europe Model) 240 V AC, 50 Hz, 70 W (UK/AUS Model)

In these specifications, 0dBV is referenced to 1.0 Volt

- (1) Specifications were determined using TEAC Test Tape YTT-2004
- (2) Specifications were determined using TEAC Test Tape YTT-2003
- (3) Specifications were determined using TEAC Test Tape YTT-8013

* dbx is a trademark of dbx, Inc.

Changes in specifications and features may be made without notice or obligation.

3 PARTS LOCATION

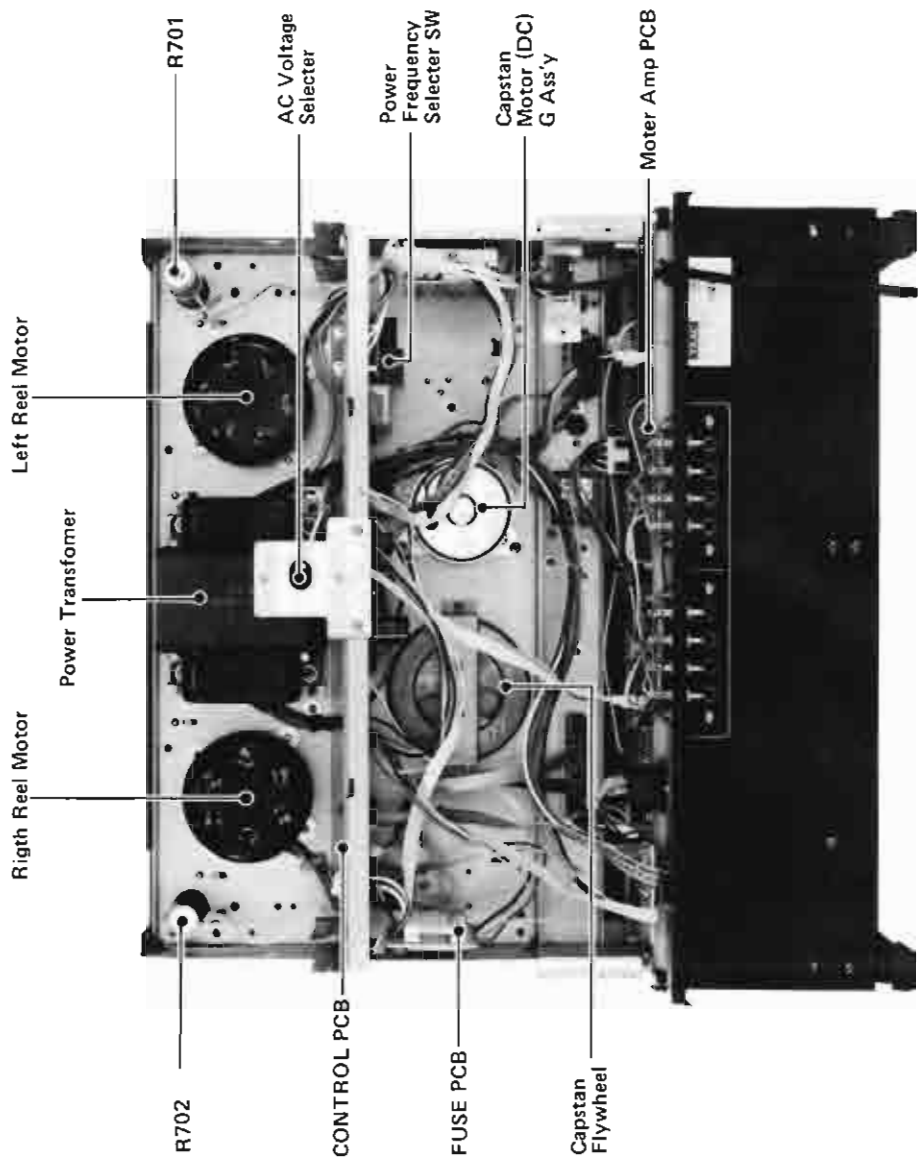

Fig. 3-1

4 REMOVAL OF EXTERNAL COMPONENTS

Disassemble in number-order

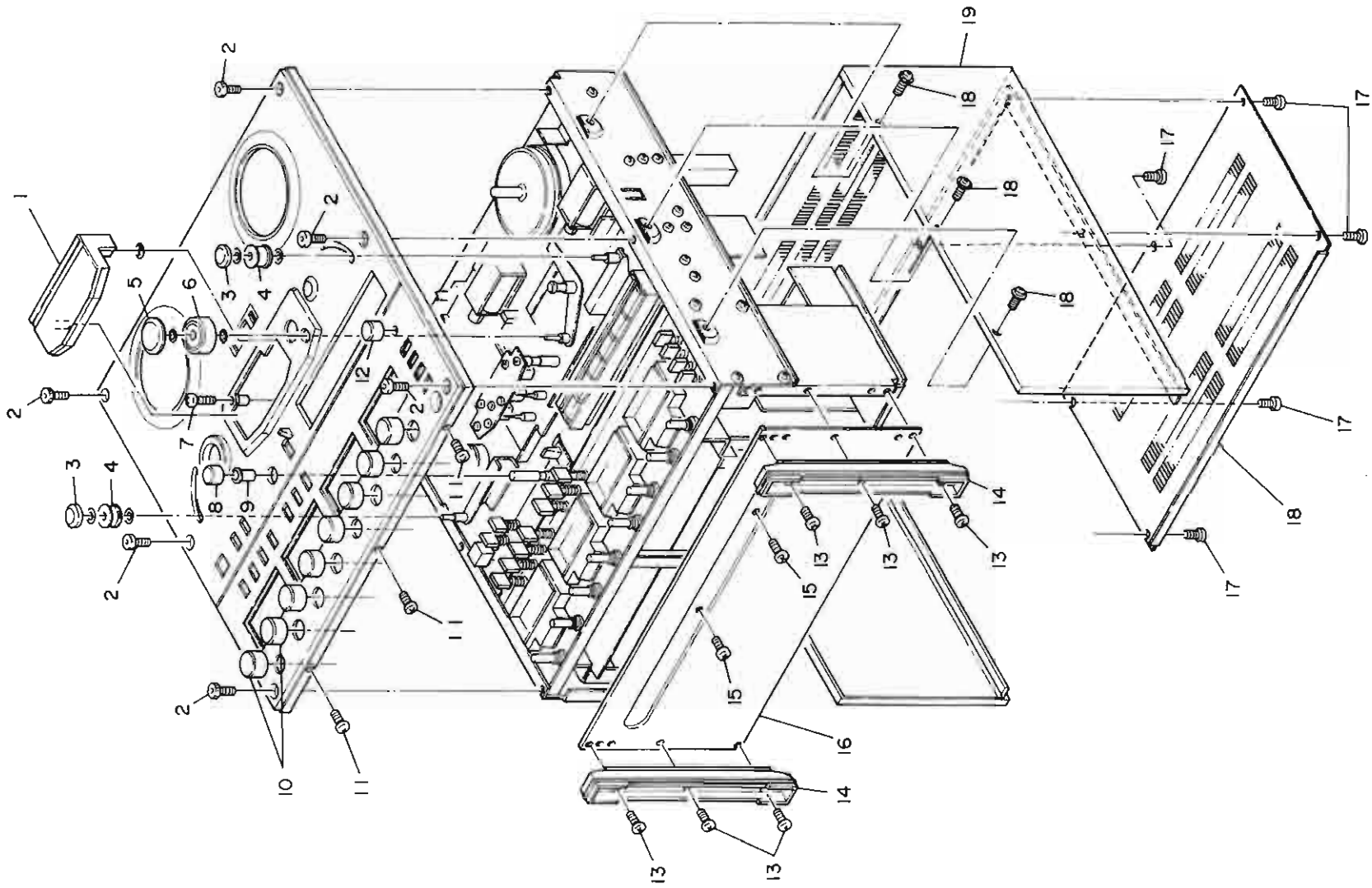

Fig. 4-1

5 MAINTENANCE

5-1 TEST EQUIPMENT

5-1-1 STANDARD EQUIPMENT

1. Spring scale (3)
 - 1) A 3-kg (7-lbs) or 4-kg (9-lbs) scale for checking pinch-roller pressure
 - 2) A 500 g (1.5-lbs) scale for checking reel torque
 - 3) A 1-kg (2.5-lbs) scale for checking brake torque
2. Empty tape reels (2)
 - 1) TEAC RE-701 (7" or 178 mm, large hub) or equivalent
 - 2) TEAC RE-702 (7" or 178 mm, small hub) or equivalent
3. Wow and flutter meter
MK-668D (Megro Denpa Sokki K.K., Japan) or Model 8155 (3M Co., Mini-com Division, USA)
4. 1-MHz digital frequency counter
Sensitivity: 0.1 V (RMS)
Impedance: Greater than 1M ohms, less than 25 pF
5. 10 Hz to 100 kHz AF oscillator
Hewlett-Packard 204C or equivalent
6. AC voltmeter
-80 dB to +40 dB (100 μ V to 100V)
Impedance: Greater than 1M ohms, less than 25 pF (HP400GL or equivalent)
7. DC voltmeter
-40 dB to +40 dB (10 mV to 100 V)
Impedance: Greater than 1M ohms, less than 25 pF
8. General-purpose attenuator
9. Distortion meter
400 Hz and 1 kHz frequencies
10. General-purpose oscilloscope
11. 1-kHz narrow band-pass filter
12. Test load resistor
4 ohms, 1 W, non-inductive (for checking headphones jack)
13. Adjustment tool (plastic)
14. Head degausser (demagnetizer)
TEAC E-1, TEAC E-3, or equivalent
15. Cleaner
TEAC TZ-261 tape recorder cleaner kit (TZ-261A for metal parts, TZ-261B for rubber parts), or TEAC HC-1 head cleaner*, TEAC RC-1 rubber cleaner*, or pure alcohol.
16. Oil
TEAC Spindle Oil (from TEAC TZ-255 Oil Kit), SAE 10W non-detergent oil, or Mobil D.T.E. Oil Light, etc.
17. Bulk tape eraser
TEAC E-2 or equivalent

Note: *USA market only



Fig. 5-1 Adjustments tool (Plastic)



Fig. 5-2 TEAC E-3 head demagnetizer

5-1-2 TEAC TEST TAPES

Note: When ordering, allow for the time required for delivery.

For tape speed and wow-and-flutter test

1. YTT-2003 For playback at 7-1/2 ips (19 cm/s)
3,000 Hz/ -5 dB
2. YTT-2004 For playback at 15 ips (38 cm/s)
3,000 Hz/ -5 dB
3. YTT-8013 For record-playback method (blank tape)

For playback head alignment

4. YTT-1044 15 ips (38 cm/s)
Reference flux: 185 nWb/m
Equalization: IEC
 $\infty + 35 \mu$ s

5. YTT-1003

7-1/2 ips (19 cm/s)
Reference flux: 185 nWb/m
Equalization: NAB
3180 μ s +50 μ s

For tape path and recording head alignment (blank tape)

6. YTT-8013 Alternate test tape: MAXELL UD35
Thickness = 35 μ m
Used with TEAC RE-701 (7-inch reel with large hub)

5-2 MECHANICAL ADJUSTMENTS AND CHECKS

5-2-1 CAPSTAN THRUST CLEARANCE

1. There must be a clearance of 0.1 to 0.3 mm between the capstan shaft and the thrust plate. Check to see that the clearance is within this range. If not, loosen the two screws on the flywheel, adjust the clearance, and retighten the screws.

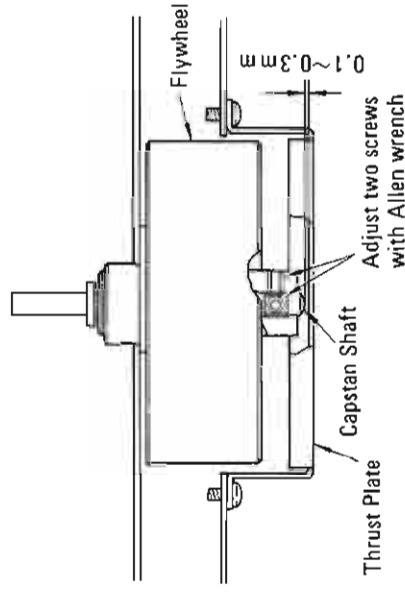

Fig. 5-3

5-2-2 SHUT-OFF SWITCH POSITION

1. There must be a clearance of 1 to 1.5 mm between the cam and actuator (A) when the microswitch is off, and 0.5 mm between the microswitch housing and actuator (B) when the microswitch is on. Check to see that the clearance is within these values. If not, adjust as necessary.

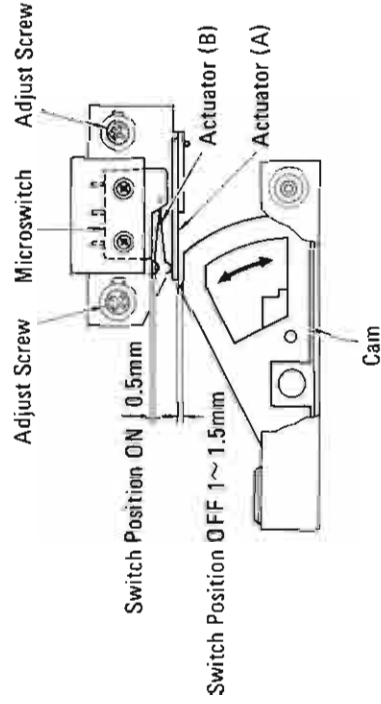

Fig. 5-4

5-2-3 BRAKE MECHANISM

Note: Be sure that the power is turned off prior to making any adjustments to the brakes.

1. Screw (A) for the left brake (as viewed from the front) must be adjusted so that there is a clearance of 1 mm between lever (C) and lever (E). Screw (A) for the right brake must then be adjusted so that lever (B) is parallel to lever (C).
2. Push the plunger until there is contact at (a); i.e., until the clearance has been eliminated, but make sure that the plunger is not pushed so strongly that the levers (E), (C), and (B) are deflected—they must remain in a horizontal plane.
3. Position the solenoid housing, while the plunger is pushed as described in step #2 above, so that the gap at (f) (the distance between the leftmost edge of the plunger and the leftmost edge of the solenoid housing) is between 11 to 12 mm. When the solenoid housing is so positioned, the plunger should be able to be depressed between 1 to 2 mm when pushed strongly.

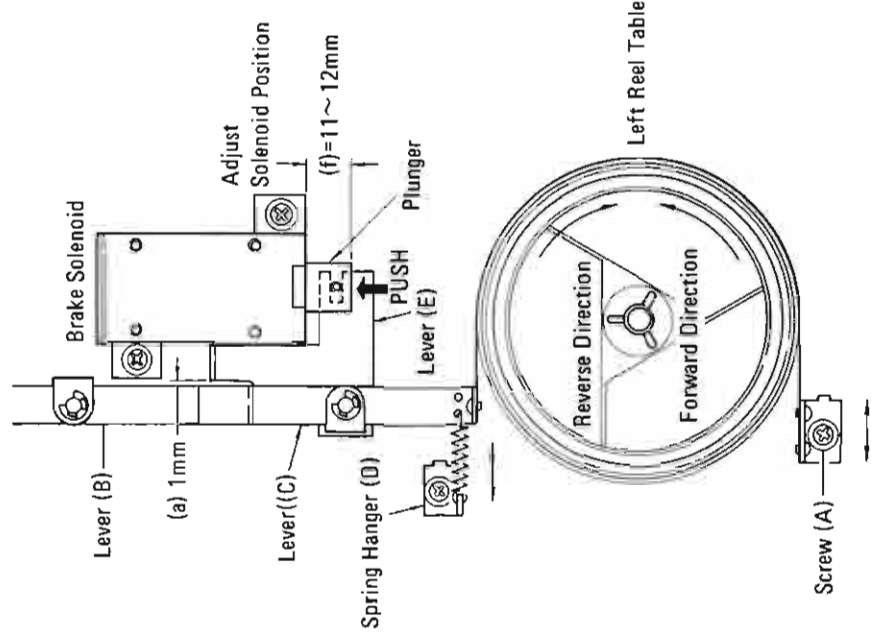
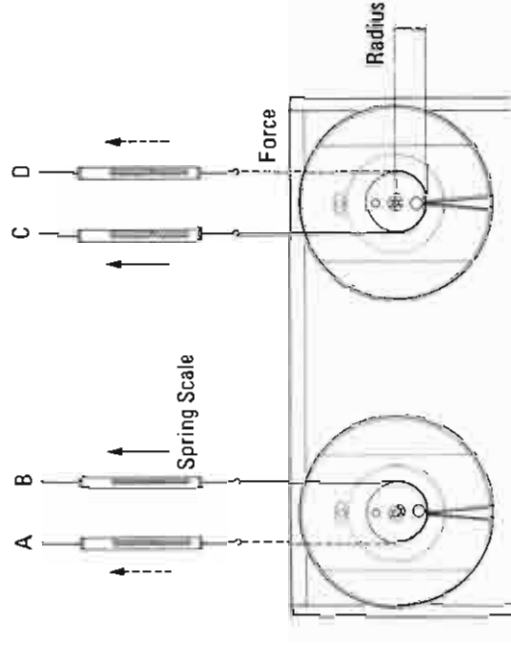

Fig. 5-5

5-2-4 BRAKE TORQUE

Note: 1. Before making any brake adjustments or measurements, make sure the power is off.

1. Mount an empty 7" reel onto either reel table and attach a spring scale to the reel with a string.
2. Smoothly pull the scale away from the reel under test and note the torque value when the reading on the scale is steady. The proper torque values are given in the chart below.
3. Follow steps 1 and 2 for each measuring condition; i.e., (A) through (D) in Fig. 5-6.
4. If the forward-direction torque is not correct, change the hooking position of the spring hanger [reference (D) in Fig. 5-5] for the corresponding brake requiring adjustment. If, after the forward-direction torque has been properly adjusted and the reverse-direction torque is not correct, or the forward-direction torque is still not correct, check to see if the brake felt pad is worn, and also check that the brake mechanism is properly aligned as explained in Section 5-2-3, "Brake Mechanism". If necessary, replace the entire reel table.



Forward direction (B) (C)	1200–1400 g-cm (16.7–19.4 oz-inch)
Reverse direction (A) (D)	500–700 g-cm (6.94–9.72 oz-inch)
Left/Right deviation	150 g-cm (2.08 oz-inch)

Torque calculating formulas:

1. Torque (in g-cm or oz-inch)
= Force or Weight (in g or oz) x Radius (in cm or inch)
2. Conversion of g-cm to oz-inch:
 $\text{g-cm} \times 0.0139 = \text{oz-inch}$

Fig. 5-6

5-2-5 REEL MOTOR TORQUE

Note: For torque calculation, refer to the formulas above.

(1) TAKE-UP TORQUE

1. Hold the right tension arm up using a rubber band.
2. Mount an empty 7" reel onto the take-up (right) reel table, and attach a spring scale to the reel with a string.
3. Place the deck in the play mode.
4. Allow the rotation of the reel to slowly pull the scale toward the reel.
5. Hold the spring scale with enough force to allow a steady reading.
6. The proper value is between 420 g-cm (5.83 oz-inch) to 550 g-cm (7.64 oz-inch).
7. There is no specially-provided adjustment for take-up torque, so if correction is needed, repair or replace the defective part and/or circuit.

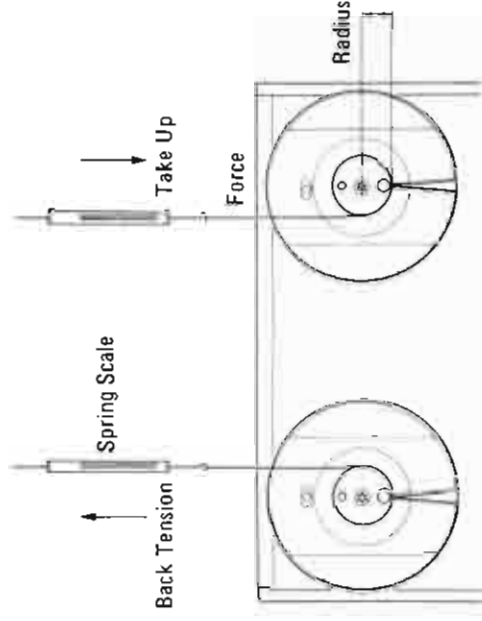

Fig. 5-7

(2) BACK TENSION

1. Hold the right tension arm up using a rubber band.
2. Mount an empty 7" reel onto the supply (left) reel table, and attach a spring scale to the reel with a string.
3. Place the deck in the play mode.
4. Using a steady, smooth motion, pull against the motor torque to draw the scale away from the reel.
5. After making sure that the reel motion is smooth (the string should not be rubbing against the reel flanges), note the value indicated on the scale.
6. The proper value is between 220 g-cm (3.06 oz-inch) to 280 g-cm (3.89 oz-inch).
7. If necessary, adjust the slider of the resistor (R701) until the proper torque value is obtained. See Fig. 5-8.

5-2-7 REEL TABLE HEIGHT

1. As a general reference, the height of the reel table should roughly correspond to a distance of 38 mm (1-1/2") between the chassis of the deck and the rubber mat on the reel table. If checking reveals any large deviation from this value, loosen the two adjustment screws on the reel table, adjust the height, and retighten the screws.
2. For fine-adjustment, check that, while in fast-forward (forward direction) or rewind (reverse direction) modes starting at the beginning of the tape, the tape does not touch the upper or lower reel flanges. If it does, fine-adjust accordingly.

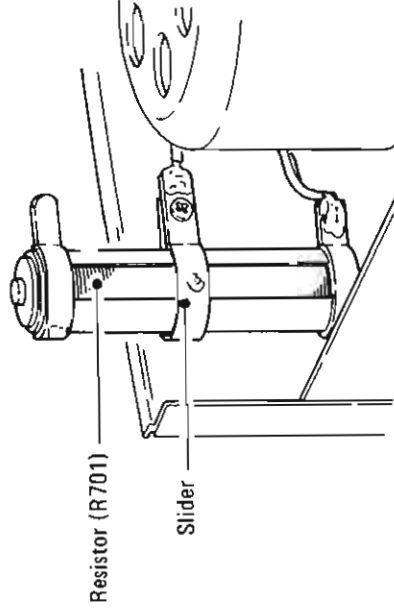

Fig. 5-8

5-2-6 PINCH ROLLER PRESSURE

1. Hold the right tension arm up using a rubber band, string, etc.
2. Place the deck in the play mode without threading any tape.
3. Attach a spring scale to the pinch roller as shown in Fig. 5-9.
4. Pull the pinch roller away from the capstan shaft (on a plane intersecting the center of the capstan shaft and the pinch roller) until the capstan shaft and the pinch roller are separated.
5. Ease pressure on the scale until the pinch roller just begins to turn. The scale should then read 1.8 kg to 2.0 kg (3-1/5/16 lbs. to 4-7/16 lbs.).

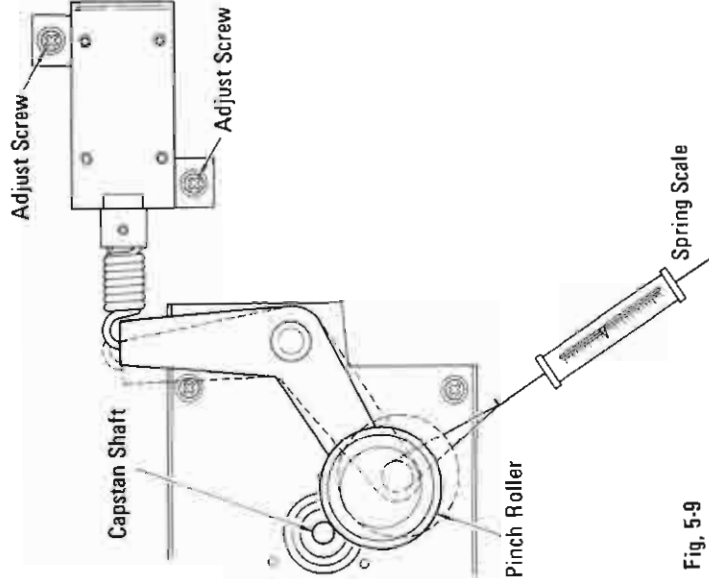

Fig. 5-9

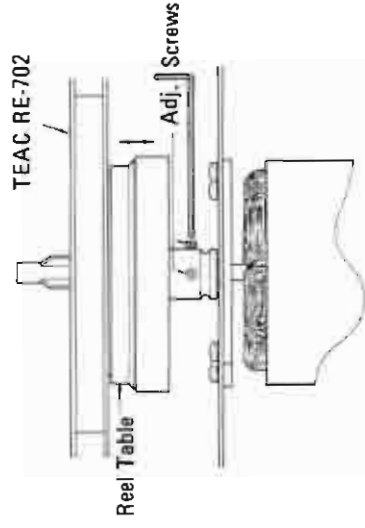

Fig. 5-10

5-2-8 TAPE SPEED

1. Connect a frequency counter to either **OUTPUT** jack (see Fig. 5-11).
2. Load a TEAC YTT-2004 test tape containing a 3000 Hz test tone, and set the **SPEED** switch to **HIGH** (38 cm/sec or 15 ips).
3. Play the middle of the test tape and adjust the **HIGH** speed trimmer resistor until the frequency counter indicates a reading of 3000 Hz. See Fig. 5-12. (**CAUTION:** Use an insulated screwdriver to prevent shorting.)
4. Playing the tape at both the beginning and the end, check that the tape speed does not vary any more than the limits prescribed in the specifications, so that there is never a total deviation of more than ± 15 Hz from the 3000-Hz test tone, nor a drift of more than 15 Hz at any given time.
5. Using a TEAC YTT-2003 test tape, repeat steps #3 and #4 above with the **SPEED** switch set to **LOW** (19 cm/sec or 7-1/2 ips). In step #3, the speed may be adjusted for the proper initial setting by using the **LOW** speed trimmer resistor.

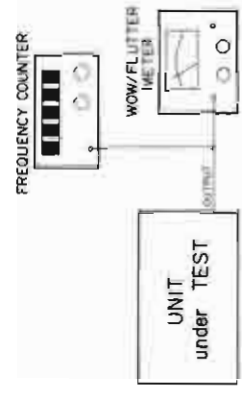

Fig. 5-11

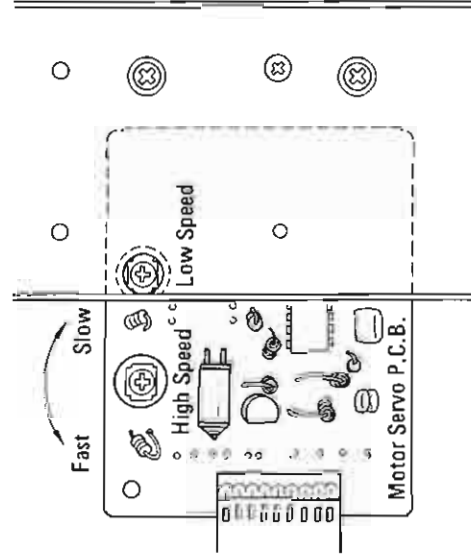

Fig. 5-12

5-2-9 WOW AND FLUTTER (PLAYBACK)

1. Connect a wow-and-flutter meter to the deck as shown in Fig. 5-11.
2. Load a TEAC YTT-2004 test tape to check the wow and flutter when the deck is set to **HIGH** speed, or a YTT-2003 test tape to check when set to **LOW** speed.
3. Play the beginning and end of the respective test tape for each speed setting. The measured wow and flutter should be no greater than 0.04% (WRMS) and 0.07% (RMS) for the **HIGH** speed setting and 0.05% (WRMS) and 0.08% (RMS) for the **LOW** speed setting.

5-2-10 HEAD AND TAPE PATH ALIGNMENT

Note: For detailed alignment principles, refer to the TEAC CORPORATION publication, **AUDIO FUNDAMENTAL, TAPE DECK**, Section 8, "Mechanical Adjustments".

(1) HEAD CONFIGURATION

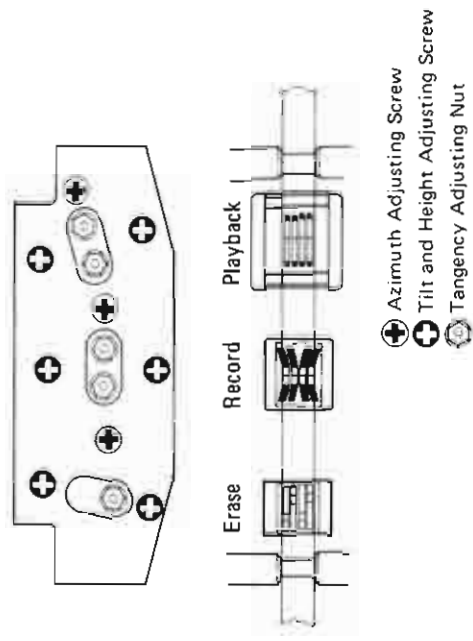

Fig. 5-13

(2) ALIGNMENT CONDITIONS

Adjust each head to satisfy each of the following conditions:

Condition	Example of Misalignment
TILT The head surface should be parallel to the tape guide pin surface.	
AZIMUTH The gap of the head core should be perpendicular to the tape path.	
HEIGHT The distance from the top head core to the top edge of the tape and from the bottom head core to the bottom edge of the tape should be equal.	
TANGENCY The dotted line should be perpendicular to the surface of the tape.	

Fig. 5-14

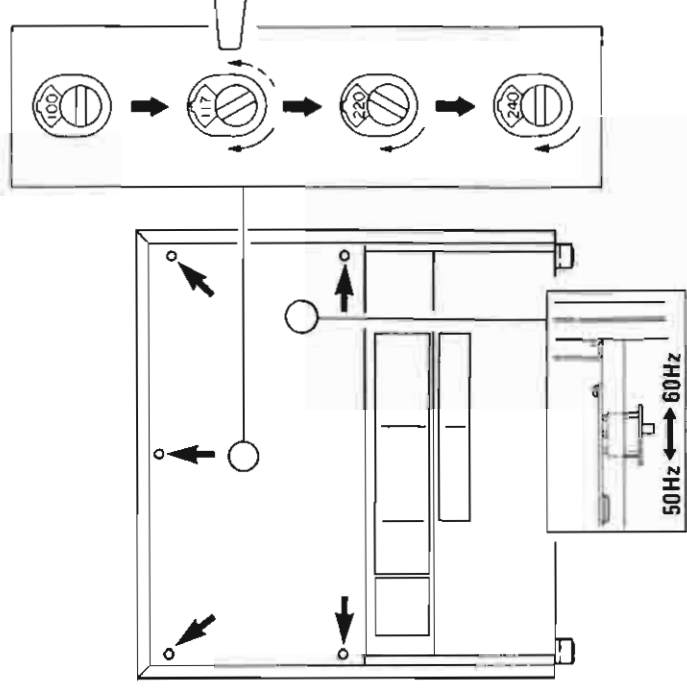

Fig. 5-15

5-2-12 LUBRICATION

Oiling is needed after every 1,000 hours of operation, or once a year if the deck is used infrequently. TEAC spindle oil (from the TEAC TZ-255 oil kit), Mobil D.T.E. Oil Light, and similar types of oil are recommended. Lubrication is normally not necessary except at the points shown. To lubricate, follow the steps below.

1. Place the deck in a horizontal position.
2. Apply a few drops of oil to the spindles indicated in Fig. 5-16, except the capstan and the reel motors. Spread the oil evenly on the spindle surfaces using a cotton cloth or similar applicator.
3. For the capstan and reel motors, apply a few drops to the indicated positions but do not spread the oil.
4. After oiling all points, operate the deck for 1 to 2 hours until the oil is thoroughly absorbed.

(3) ALIGNMENT PROCEDURE

1. By visual observation, align the erase, record, and play heads so that the proper tilt is obtained for each.
2. Coarse-adjust the azimuth of the erase, record, and play heads by observing each without a tape threaded.
3. Load a TEAC YTT-8013 test tape and play it.
4. Find-adjust the height of all heads, referring to the explanation in Fig. 5-14. This adjustment should be made by equally turning all the appropriate screws so as not to alter the tilt and azimuth adjustments previously made.
5. If required, make a coarse adjustment of any head requiring tangency correction, while the tape is running.

5-2-11 VOLTAGE AND FREQUENCY CONVERSION

(For general export models only)

ALWAYS DISCONNECT POWER LINE CORD BEFORE MAKING THESE CHANGES.

1. Remove the rear metal cover of the deck by removing the five securing screws.
2. Locate the voltage selector, shown in the illustration, at the center of the deck as seen from the rear.
3. Turn the slotted center post of the selector until the desired voltage is indicated by the selector.
4. Locate the frequency selector slide switch which is on the control PCB near the center of the rear section of the deck.
5. Set the slide switch to the left for 50 Hz or to the right for 60-Hz operation. Proper frequency adjustment is required for the AC reel motors. The capstan motor of the 22-4 is a DC motor and therefore does not require adjustment to match the AC line frequency.
6. Replace the cover and retighten the screws.

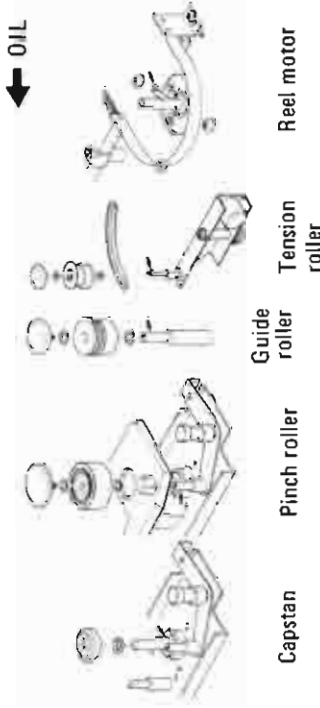

Fig. 5-16

5-3 ELECTRICAL ADJUSTMENTS AND CHECKS

5-3-1 PRECAUTIONS

1. Check that the deck is properly set for the voltage in your locality.
2. The AC voltmeter used in the procedures must have an input impedance of 1M ohms or more.
3. 0 dB is referenced to 1 V. If using an AC voltmeter with 0 dB referenced to 0.775 V, appropriate compensation should be made.
4. All the procedures refer only to channel 1, the same procedures also apply to channels 2, 3 and 4 unless explicitly stated otherwise.
5. Unless otherwise stated, use the basic test setup (Fig. 5-17), where the 1-kHz filter is bypassed.
6. When the 1-kHz filter in the basic test setup is switched ON, note the following:
 - 1) The test signal from the AF oscillator should be tuned to the filter used.
 - 2) Do not overlook filter loss when making measurements.

-70 dB or more . . . What does it mean?

In reference to some specifications, you may come across an expression like: “-70 dB or more”. This means that the lower the value of this specification, the greater the absolute value of the specification and the better the performance of the deck. For instance, a noise floor of -76 dB is better than -70 dB, because this means that the level of noise is lower. So in this case, “-70 dB or more” means at least as good a value as -70 dB and maybe even better, i.e., -71 dB.

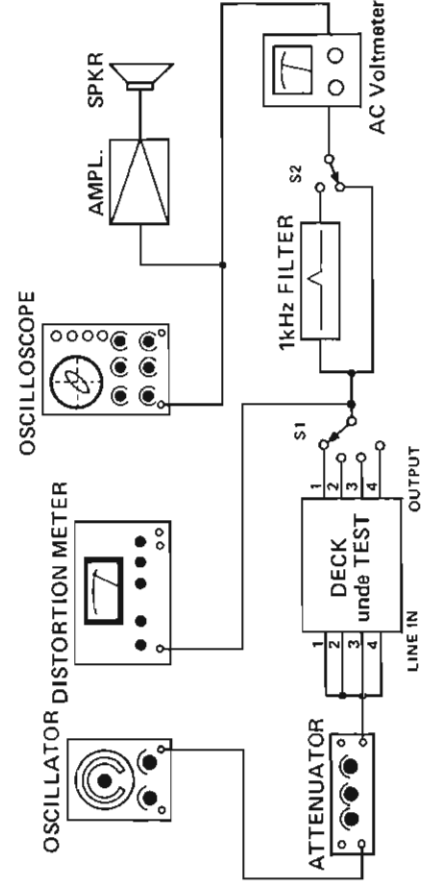

Fig. 5-17 Basic test setup

5-3-2 MONITOR PERFORMANCE

Initial switch/control settings:

FUNCTION SELECT switches # 1 to # 4 . . . OFF
 OUTPUT SELECT switches SOURCE
 INPUT controls # 1 to # 4 Minimum
 OUTPUT controls # 1 to # 4 Minimum

(1) LINE INPUT LEVEL

Connection: Designated in the procedure.

1. Remove the special U-link plug connecting ENCODER SEND jack 1 and ENCODER RCV jack 1.
2. Connect an AF oscillator via an attenuator to LINE IN jack 1, and an AC voltmeter to ENCODER SEND jack 1.

3. Set INPUT control 1 to position “7”.
4. Apply a 400-Hz, -10 dB (316 mV) signal to LINE IN jack 1.
5. Adjust R194 for -10 dB (316 mV) at ENCODER SEND jack 1.
6. Turn INPUT control 1 to the maximum position.
7. Check that the AC voltmeter reading is 0 dB \pm 3 dB (708 mV to 1.41 V).
8. Return INPUT control 1 to position “7” so that the AC voltmeter reads -10 dB. This is the specified INPUT control setting.

IMPORTANT:

Do not alter the INPUT control during subsequent checks.

(2) OUTPUT AMPLIFIER GAIN

1. Check that the special U-link plug is inserted between ENCODER SEND jack 1 and ENCODER RCV jack 1.
2. Depress OUTPUT SELECT: SOURCE.
3. Set the OUTPUT control to position "7".
4. Apply a 400-Hz, -10 dB (316 mV) signal to LINE IN jack 1.
5. Adjust R149 for -10 dB (316 mV) at OUTPUT jack 1.
6. Turn OUTPUT control 1 to position "10".
7. Check that the AC voltmeter reads 0 dB \pm 3 dB (708 mV to 1.41 V).
8. Return OUTPUT control 1 to position "7" so that the AC voltmeter reads -10 dB. This is the specified OUTPUT control setting.

IMPORTANT:

Do not alter either the INPUT control setting made in step 5-3-2 (1) nor the OUTPUT control setting until all the rest of the adjustments have been completed.

(3) VU METER

9. Adjust R159 so that the VU meter reads 0 VU.

(4) OUTPUT LEVEL AT PHONES JACK

Connection: Designated in the procedure.

1. Set the MONITOR control to position "10".
2. Connect a 4-ohm non-inductive resistor to the 2-conductor phone plug as shown in Fig. 5-18, and insert this plug into the PHONES jack.
3. Depress the MONITOR selector button for channel 1.
4. Using an AC voltmeter, measure the output level across the test load resistor.
5. The AC voltmeter should indicate -15.7 dB \pm 3 dB (116 mV to 232 mV).
6. Depress all 4 MONITOR selector buttons.
7. The AC voltmeter reading should be -3.7 dB \pm 3 dB (462 mV to 923 mV).

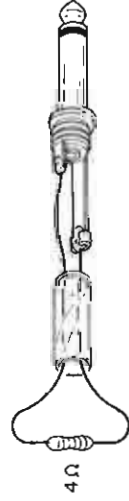

Fig. 5-18 Test connections for PHONES output check

5-3-3 PLAYBACK PERFORMANCE

Initial switch/control settings:

OUTPUT SELECT switches. **PLAY**
INPUT controls #1 to #4 . . . Specified position
 [See 5-3-2 (1)]
OUTPUT controls #1 to #4. . . Specified position
 [See 5-3-2 (2)]

(1) PLAY HEAD AZIMUTH

Connection: Fig. 5-19

Note: Before beginning the following head alignment procedure, be sure that the heads have been properly mounted with reference to height, tilt and tangency. See pages 13.

SPEED switch: LOW

1. Remove the head housing covering the head assembly.
2. Thread a YTT-1003 test tape.
3. Visually check that the head wire/phase is correct.
4. Play the 16-kHz, -10 dB test tone in the 2nd test section of the test tape.
5. Slowly rotate the azimuth screw until the AC voltmeter approximates the maximum value at each track.
6. Playing 400-Hz to 6-kHz frequencies, adjust the azimuth screw until the oscilloscope shows that the signals between tracks 1 and 3 (then between tracks 2 and 4) are less than 45 degrees out of phase for these signals.

SPEED switch: HIGH

7. Repeat the above steps, but use the following substitutions:

Test tape. YTT-1004
 Frequency limits in step 6. . . 400 Hz to 8 kHz
 8. Secure the screw with a drop of locking paint.

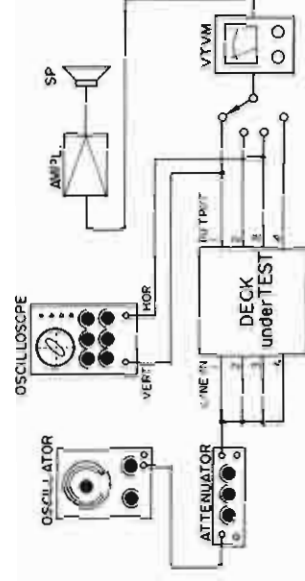

Fig. 5-19 Head phase check setup

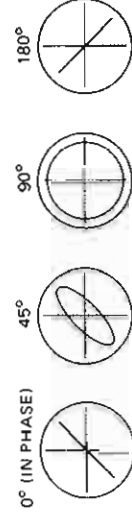

Fig. 5-20 Confirming phase relationship

(2) PLAYBACK LEVEL

Connection: Designated in the procedure.

SPEED switch: LOW

1. Check that the specified output level setting is used. See item 5-3-2 (2), step 8.
2. Remove the special U-link plug connecting the DECODER SEND and RCV jacks (channel 1) at the rear of the deck.
3. Connect an AC voltmeter to the DECODER SEND jack 1.
4. Play the 400-Hz, 0 dB tone in section 1 of the YTT-1003 test tape.
5. Adjust R143 for -10 dB (316 mV) at DECODER SEND jack 1.
6. Insert the special U-link plug between the DECODER SEND and RCV jacks (#1).
7. Change the AC voltmeter connection to OUTPUT jack 1.
8. Check that the output level is -10 dB (316 mV) at OUTPUT jack 1.

(3) VU METER

9. Check that VU meter 1 reads 0 VU.

(4) FREQUENCY RESPONSE

Note: The prescribed specifications are shown in Fig. 5-21.

SPEED switch: HIGH

10. While playing a YTT-1044 test tape, adjust R117 so that the reading on the AC voltmeter is within the prescribed specifications.

Note: If the response is not uniform, the head should be checked for accumulated dirt or oxide. If clean, head azimuth should be readjusted.

SPEED switch: LOW

11. Using a TEAC YTT-1003 tape, adjust R122 in the same way as above.

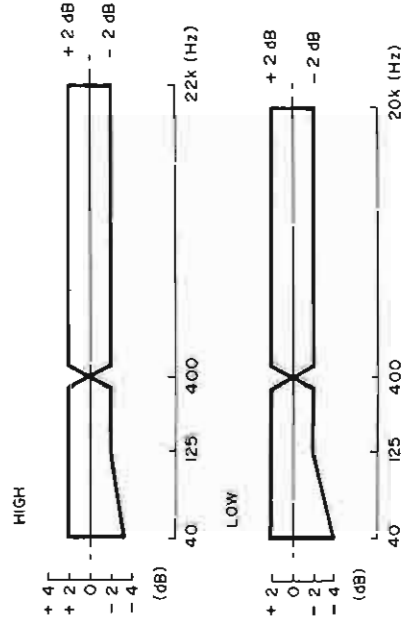

Fig. 5-21 Frequency response (Playback)

(5) SIGNAL-TO-NOISE RATIO

SPEED switch: HIGH

1. The OUTPUT controls should be set to the specified positions. See 5-3-2 (2).
2. Hold the shut-off arm (right) in the up position with no test tape threaded.
3. Depress the play button.
4. The AC voltmeter should indicate a minimum value of -60 dB (or more), or 1.00 mV (or less).
5. This corresponds to a minimum signal-to-noise ratio of 50 dB. This is the difference between the inherent noise of -60 dB and the specified output level of -10 dB (316 mV).

SPEED switch: LOW

6. Repeat steps 4 to 5. The prescribed specifications are the same as that for the HIGH speed setting.

5-3-4 RECORDING PERFORMANCE

Initial switch/control settings:

FUNCTION SELECT switches #1 to #4	.. ON
OUTPUT SELECT switches PLAY
INPUT controls #1 to #4
Specified position [See 5-3-2 (1)]	
OUTPUT controls #1 to #4
Specified position [See 5-3-2 (2)]	

(1) BIAS TRAP

Connection: Designated in procedure

1. Remove all input signals.
2. Thread a YTT-8013 test tape on the deck and simultaneously press the RECORD and PAUSE buttons, enabling the RECORD/PAUSE mode.
3. Connect an AC voltmeter or oscilloscope from ground to the BIAS TRAP test point on the REC/PLAY AMP PCB assembly. For the test point location, see Fig. 5-24.
4. Adjust L103 so that a minimum reading is obtained on the scope or AC voltmeter. Use a plastic adjustment tool.
5. Set the deck in the REC/PLAY mode.
6. Connect an AC voltmeter to the OUTPUT jacks.
7. Adjust L101 so that the bias leakage is -42 dB (or more), or 7.94 mV (or less).

(2) RECORD HEAD AZIMUTH

Connection: Fig. 5-19

SPEED switch: HIGH

1. Check that the play head azimuth adjustment is correct. See 5-3-3 (1).
2. Visually check that the head wire/phase is correct.
3. Apply and record a 16-kHz, -30 dB (31.6 mV) signal on a YTT-8013 test tape.
4. Adjust the azimuth screw (see Fig. 5-13) so that the phase relationship between tracks 1 and 3, then between tracks 2 and 4, is within 45 degree on the oscilloscope, and so that the maximum value in on both tracks is approximated on the AC voltmeter.
5. Check that the phase relationship from 400 Hz to 5kHz is within 45 degree.
6. Secure the screw with a drop of locking paint.

(3) RECORD BIAS

SPEED switch: LOW

1. Apply a 7-kHz, -20 dB (100 mV) signal.
2. Turn C381 (for track 1 — the points for the other tracks are indicated below) fully counterclockwise.
3. While recording on a YTT-8013 test tape, slowly turn C381 clockwise until the reading on the AC voltmeter peaks, and continue turning clockwise until the reading backs off 2 to 3 dB.
C382: for track 2
C383: for track 3
C384: for track 4

(4) RECORD LEVEL

SPEED switch: LOW

4. Check that the INPUT and OUTPUT controls are still at their specified positions.
5. Apply a 400-Hz, -10 dB (316 mV) signal.
6. While recording, adjust R206 so that an output level of -10 dB (316 mV) is obtained at the OUTPUT jacks.

(5) FREQUENCY RESPONSE

Note: The prescribed specifications are shown in Fig. 5-22.

SPEED switch: LOW

7. Record a signal sweeping from 40 Hz to 20 kHz at -20 dB (100 mV) on a YTT-8013 test tape.
8. During recording, monitor the off-the-tape signal and adjust L102 so that a reading within the prescribed specifications is obtained.
9. With FUNCTION SELECT switch #1 in the OFF position (but #2, #3 and #4 are in the ON position), adjust L381 so that the frequency response of all channels except channel #1 are within the prescribed specifications.

10. Repeat the above procedure 3 times, successively setting switch #2, then #3, then #4 to OFF. The adjustment point changes each time, corresponding to the particular switch that has been set to OFF as follows:
 - Switch #2 for channel 2 L382
 - Switch #3 for channel 3 L383
 - Switch #4 for channel 4 L384

SPEED switch: HIGH

11. Repeat the above procedure (steps 7 to 10), but record a test signal sweeping from 40 Hz to 22 kHz at -10 dB (316 mV).
12. Continue steps 7 to 11 until the frequency response at both speeds is within specification.

Note: If the response is not within the prescribed specifications, the heads should be checked for accumulated dirt and oxide and the bias readjusted.

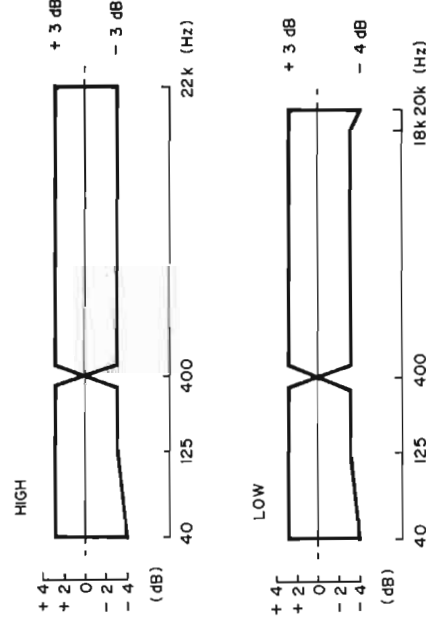

Fig. 5-22 Frequency response (Overall)

(6) TOTAL HARMONIC DISTORTION

SPEED switch: LOW

1. Thread a YTT-8013 test tape.
2. With the INPUT and OUTPUT controls set to the specified positions, apply a 1-kHz signal at -10 dB, 316 mV (0 VU) to the LINE IN jacks.
3. Place the deck in the record mode for approximately 10 seconds.
4. Rewind and play this recorded section of the tape.
5. The distortion factor read on the distortion meter should be 1.0% or less.

(7) SIGNAL-TO-NOISE RATIO

SPEED switch: HIGH

1. The **INPUT** and **OUTPUT** controls should be at the specified positions.
2. Record a 1-kHz signal at -10 dB (316 mV) on a YTT-8013 test tape, then make a “no signal” recording.
3. Rewind the recording made in step 2 to the beginning and play it back.
4. Make sure the playback output level of the previously recorded 1-kHz signal is -10 dB (316 mV), and measure the level of the “no signal” portion of the tape.
5. Note the difference in the output level between the 1-kHz portion and the “no signal” portion.
6. The signal-to-noise ratio should be at least 45 dB.

SPEED switch: LOW

7. Repeat the above sequence with the deck set to **LOW** speed to obtain the S/N ratio at this setting.
8. The signal-to-noise ratio should be at least 46 dB.

Note: If the output is connected to the AC voltmeter through a band-pass filter (with cut-off frequencies of 20 Hz and 20 kHz), and a NAB weighting network device, the signal-to-noise ratio measurement will yield higher values. For example, at the **HIGH** speed setting, it would be improved from 45 dB to 51 dB. This 51 dB value corresponds to 61 dB, weighted, at a 3% THD level (10 dB above 0 VU).

(8) ERASE EFFICIENCY

Connection: The same as in Fig. 5-17, but switch on the 1-kHz filter.

SPEED switch: HIGH

1. Check that the **INPUT** and **OUTPUT** controls are set to their specified positions.
2. Thread a YTT-8013 test tape on the deck.
3. Apply a 1-kHz signal at 10 dB above the specified level of -10 dB (316 mV); i.e., 0 dB (1 V).
4. Make a 30-second recording of this signal and rewind to the beginning of the recording.
5. Disconnect the 1-kHz signal source from the **LINE IN** jacks.
6. Put the deck in the record mode and erase a portion of the previous recording, then rewind to the beginning again.
7. Put the deck in the play mode and monitor the output on the AC voltmeter.
8. The AC voltmeter reading of the erased portion should be a minimum of -70 dB (or more), or $316 \mu\text{V}$ (or less). This is equivalent to a minimum erasing ratio of 70 dB; i.e., the difference between the reference output level of 0 dB and residual signal level of -70 dB.

(9) CHANNEL SEPARATION

Connection: Fig. 5-17 with 1-kHz filter switched ON.

SPEED switch: HIGH

1. Be sure that all **FUNCTION SELECT** switches are the **ON** position and that the **OUTPUT** and **INPUT** controls are still at their specified positions.
2. Thread a YTT-8013 test tape.
3. Apply a 1-kHz signal at -10 dB (316 mV) to all channels except channel 2.
4. Place the deck in the record mode for several seconds then rewind the tape to the beginning of the recorded portion.
5. Play the tape and measure the output from channel 2 with an AC voltmeter. The level should be a minimum of -50 dB (or more) or 3.16 mV (or less). That is the channel separation should be at least 40 dB (the difference between the specified output level of -10 dB and the level of signal leakage from channel 2 of -50 dB).
6. Repeat the above steps, substituting channel 3 for channel 2.

5-3-5 SIMUL-SYNC PERFORMANCE

Initial switch/control settings:

FUNCTION SELECT switches #1 to #4 . . . ON
 OUTPUT SELECT switches SYNC
 INPUT controls #1 to #4 . . . Specified position
 [See 5-3-2 (1)]
 OUTPUT controls #1 to #4 . . . Specified position
 [See 5-3-2 (2)]

(1) PLAYBACK LEVEL

SPEED switch: LOW

1. Play the 400-Hz, 0 dB tone in section 1 of the YTT-1003 test tape.
2. Adjust R345 for -10 dB (316 mV) at the OUTPUT jack for channel 1, and R346 for channel 2, R347 for channel 3, and R348 for channel 4.

(2) FREQUENCY RESPONSE

Note: The prescribed specification is shown in Fig. 5-23.

SPEED switch: HIGH

3. Apply a signal sweeping from 50 Hz to 8 kHz at -10 dB (316 mV) and record it on the YTT-8013 test tape.
4. Rewind the tape to the starting portion of the recording.
5. Play the tape and check that the frequency response is within the prescribed specification.

SPEED switch: LOW

6. Repeat the above steps, but apply a test signal at -20 dB (100 mV).

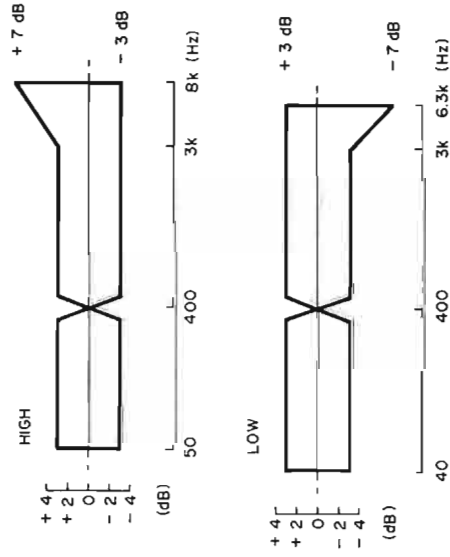

Fig. 5-23 Frequency response (SYNC performance)

(3) SIGNAL-TO-NOISE RATIO

SPEED switch: HIGH

1. The OUTPUT control should be at the specified output level setting.
2. Hold the shut-off arm (right) in the up position with no test tape threaded.
3. Press the play button.
4. The AC voltmeter connected to OUTPUT jack 1 should indicate -55 dB (or more) or 1.78 mV (or less).
5. This corresponds to a signal-to-noise ratio of 45 dB; i.e., the difference between the residual noise of -55 dB and the specified output level of -10 dB (316 mV).

SPEED switch: LOW

6. Follow the above procedures with the deck set at LOW speed. The specifications are the same as for HIGH speed.

(4) CHANNEL SEPARATION

1. With the OUTPUT SELECT: SYNC button depressed, repeat the procedures described on page 18, section 5-3-4 (9).

(5) SYNC CROSSTALK

1. Apply a 1-kHz, -10 dB (316 mV) signal from the AF oscillator to LINE IN jacks 1, 3 and 4.
2. Place the deck in the REC/PAUSE mode.
3. Ensure that the FUNCTION SELECT switch for channel 2 is OFF.
4. Note the difference in level between the output from OUTPUT jack 2 and the specified output level of -10 dB (316 mV). The difference should be 11 dB or more.
5. Repeat this procedure by applying signals to LINE IN jacks 1, 2 and 4, and measuring the output at OUTPUT jack 3.

5-4 ADJUSTMENT AND TEST POINT LOCATIONS

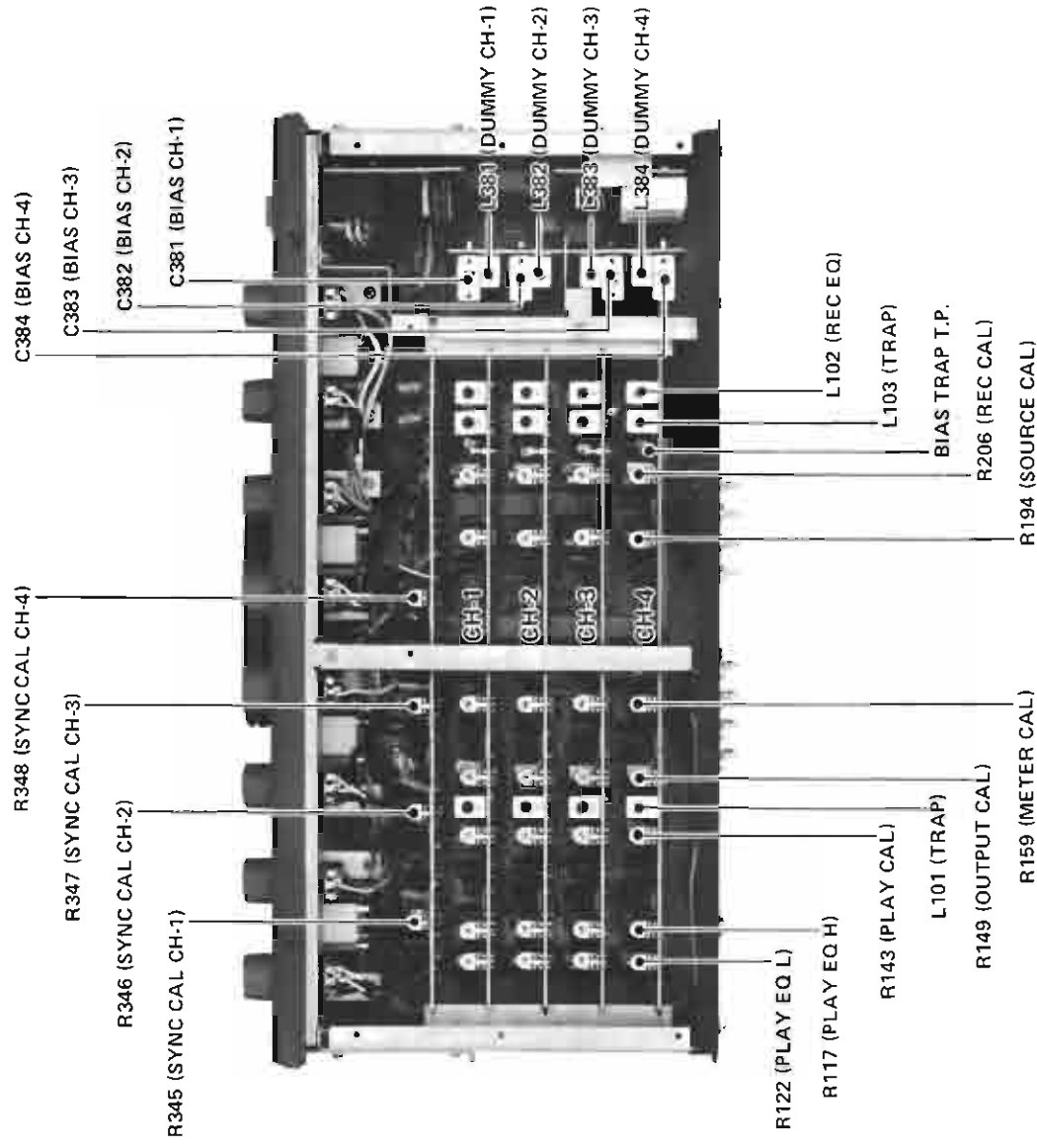
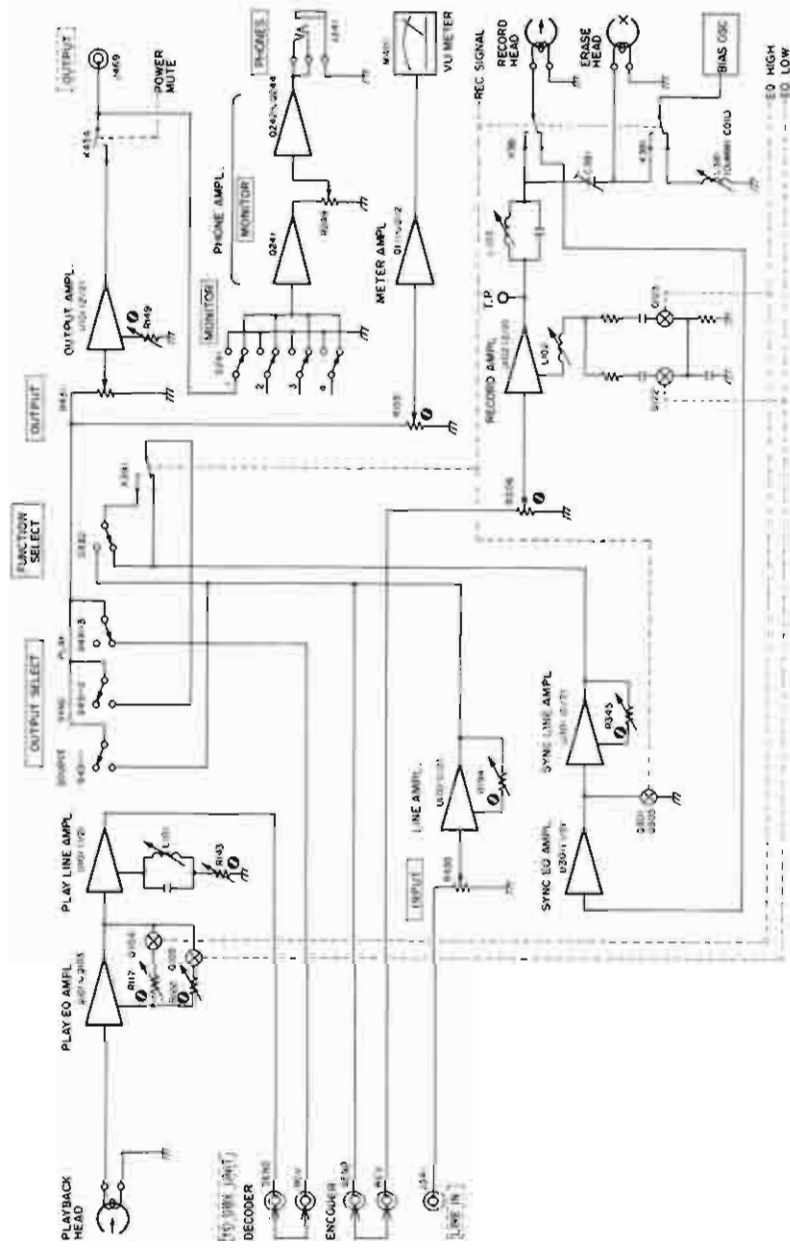
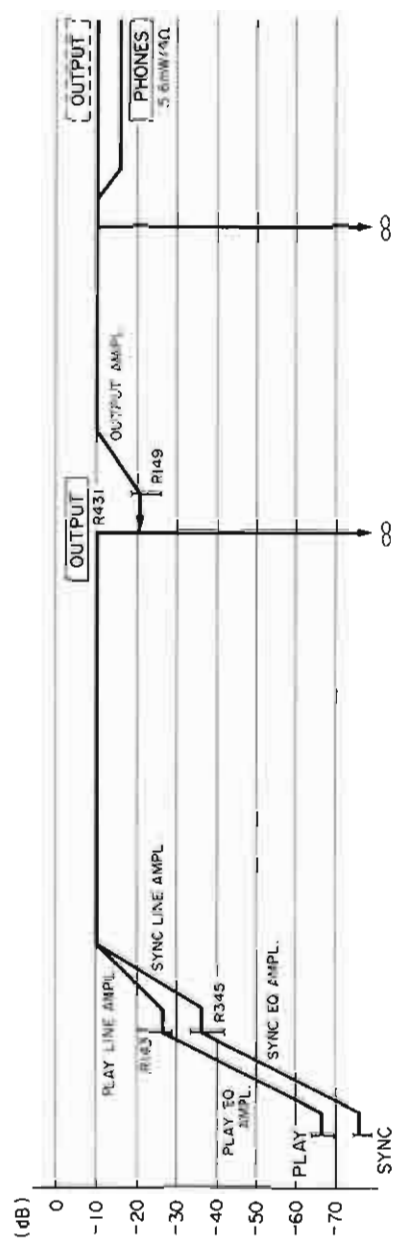

Fig. 5-24

5-5 LEVEL DIAGRAM



PLAYBACK PERFORMANCE



RECORD PERFORMANCE

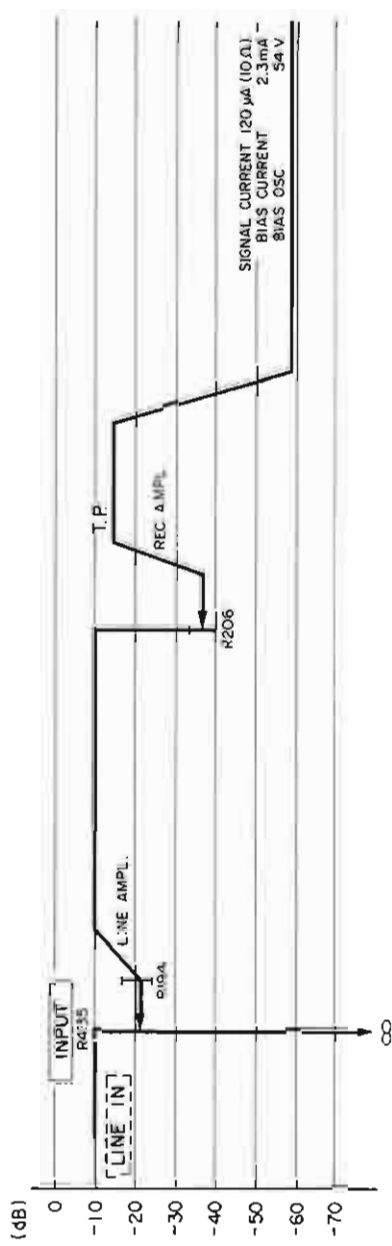

Fig. 5-25

5-6 BLOCK DIAGRAM

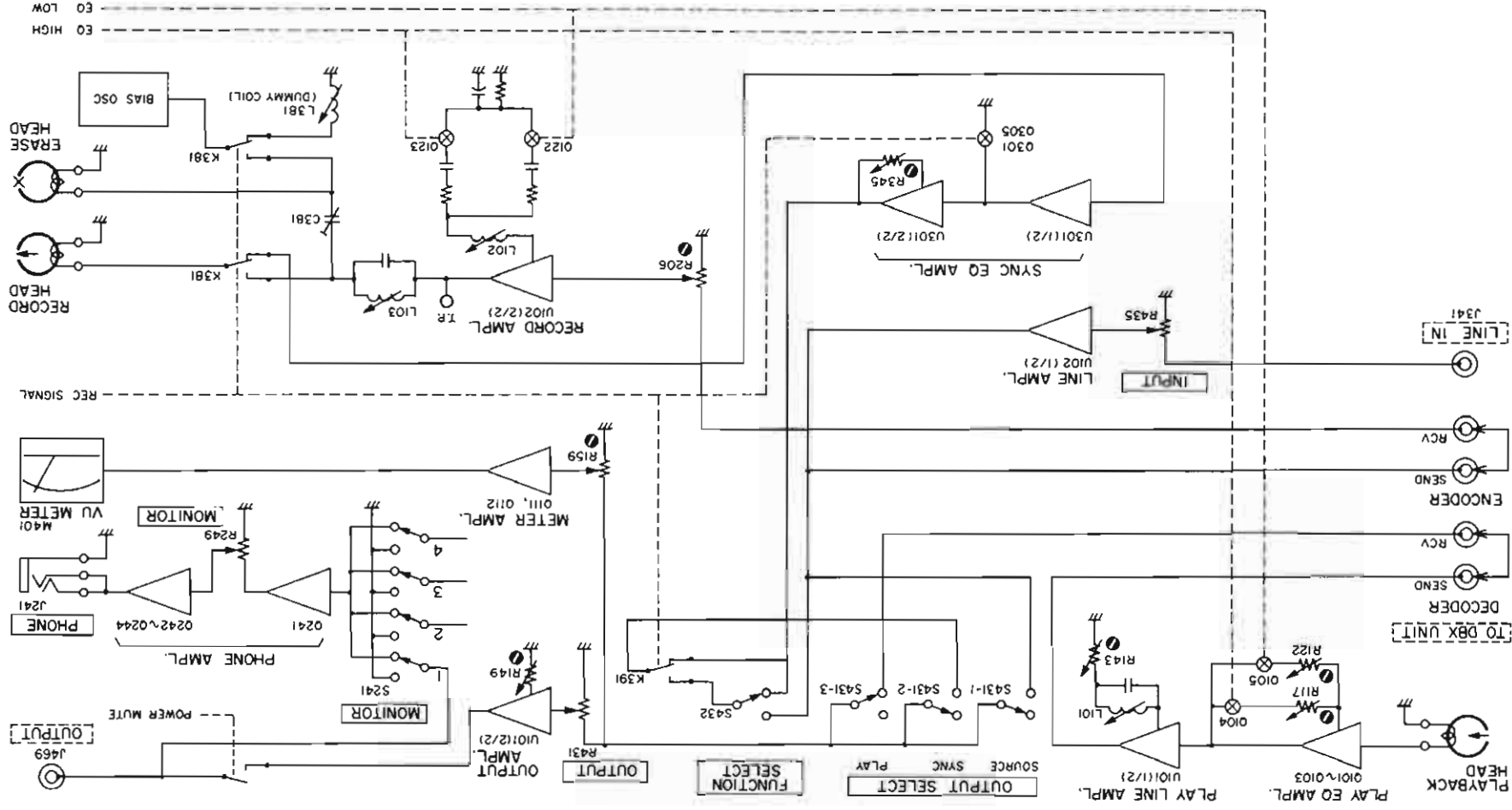

Fig. 5-26

CIRCUIT DESCRIPTION SECTION

6 TAPE TRANSPORT CIRCUIT DESCRIPTION

6-1 SYSTEM CONTROL IC

6-1-1 TERMINAL ASSIGNMENTS AND BLOCK DIAGRAM

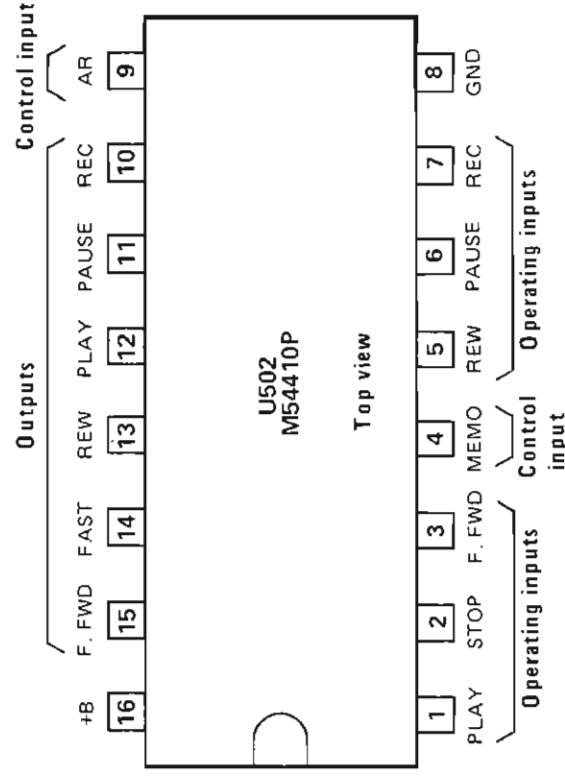

Fig. 6-1 Terminal configuration

Terminal No.	Terminal name	Function
1	PLAY	Inputs a signal to initiate playback
2	STOP	Inputs a signal to stop operation in any mode
3	F.FWD	Inputs a signal to initiate fast-forward winding
5	REW	Inputs a signal to initiate rewinding
6	PAUSE	Inputs a signal to initiate PAUSE mode
7	REC	Inputs a signal to initiate record mode
4	MEMO	Inputs a memory signal (when LOW, REW mode is reset)
9	AR	Inputs a signal controlling recording status (LOW: recording is disabled, HIGH: recording is enabled.)
10	REC	Outputs a HIGH signal in REC/PLAY or REC/PAUSE modes
11	PAUSE	Outputs a HIGH signal in PAUSE mode
12	PLAY	Outputs a HIGH signal in PLAY mode
13	REW	Outputs a HIGH signal in REW mode
14	FAST	Outputs a HIGH signal in REW or F.FWD modes
15	F.FWD	Outputs a HIGH signal in F.FWD mode
8	GND	Grounding
16	+B	Power reception (nominal: +5 V \pm 10%, absolute maximum: +7.0 V)

6-1-2 PERFORMANCES PROPER TO RESPECTIVE INPUTS

Input signal	REC	PAUSE	PLAY	REW	FAST	F.FWD	Operating mode
PLAY	L	L	H	L	L	L	PLAY mode
STOP	L	L	L	L	L	L	STOP mode
F.FWD	L	L	L	L	H	H	F.FWD mode
REW	L	L	L	H	H	L	REW mode
PAUSE	L	H	L	L	L	L	PAUSE mode
REC and PLAY	H	L	H	L	L	L	REC/PLAY mode
REC and PAUSE	H	H	L	L	L	L	REC/PAUSE mode

Note 1: The operating mode begins on the falling edge of the input signal.

Note 2: The output signals remain unchanged until an input signal changes the operating mode.

Note 3: The REC output signal stays LOW as long as the AR input signal is LOW.

Note 4: The REW output signal stays LOW as long as the MEMO input signal is LOW.

6-1-3 CHANGE OF OPERATING MODE

The following table shows how the operating modes are changed by the respective inputs signals.

Input signal	Present mode	STOP	F.FWD	REW	PLAY	PAUSE	PLAY	PAUSE	REC/PLAY	REC/PAUSE
STOP		STOP	STOP	STOP	STOP	STOP	STOP	STOP	STOP	STOP
F.FWD		F.FWD	F.FWD	F.FWD	F.FWD	F.FWD	F.FWD	F.FWD	F.FWD	F.FWD
REW		REW	REW	REW	REW	REW	REW	REW	REW	REW
PLAY		PLAY	PLAY	PLAY	PLAY	PLAY	PLAY	PLAY	PLAY	REC/PLAY
PAUSE		PAUSE	PAUSE	PAUSE	PAUSE	PAUSE	PAUSE	PAUSE	REC/PAUSE	REC/PLAY
REC and PLAY		REC/PLAY	REC/PLAY	REC/PLAY	REC/PLAY	REC/PLAY	REC/PLAY	REC/PLAY	REC/PLAY	REC/PLAY
REC and PAUSE		REC/PAUSE	REC/PAUSE	REC/PAUSE	REC/PAUSE	REC/PAUSE	REC/PAUSE	REC/PAUSE	REC/PAUSE	REC/PAUSE

Note: a square with a slanted line indicates there is no change in the operating mode.

6-1-4 MULTIPLE INPUT

The deck is in the operating mode, given in the table below, when more than one input signal is received simultaneously. When a multiple input has been received, the input signal which remains uncanceled last, becomes effective and the associated mode is entered, except in the following cases: regardless of the sequence of cancelling input signals, the REC/PLAY or REC/PAUSE mode is entered after multiple input of REC and PLAY or PAUSE has been released, and the F.FWD (REW) mode is entered after release of multiple input of F.FWD (REW) and REC or PAUSE.

Input signal A	Input signal(s) B	Resulting mode
STOP	Any combination of F.FWD, REW, REC, PAUSE, and/or PLAY	STOP mode
F.FWD	REW	STOP mode
	REC and/or PAUSE	F.FWD mode
	PLAY	STOP mode
REW	REC and /or PAUSE	REW mode
	PLAY	STOP mode
REC	PAUSE	REC/PAUSE mode
	PLAY	REC/PLAY mode
	PAUSE and PLAY	REC/PAUSE mode
PAUSE	PLAY	REC/PLAY mode

6-1-5 INPUT/OUTPUT LEVELS

Input/output levels and power requirements are summarized below.

Type of voltage	Minimum	Nominal	Maximum	Absolute maximum
Supply	4.5 V	5.0 V	5.5 V	7.0 V
Input	—	—	—	5.5 V
Input (LOW)	—	—	0.8 V	—
Open input	3.2 V	—	—	—
Output (HIGH)	2.9 V	—	—	—
Output (LOW)	—	—	0.4 V	—

6-2 INITIAL RESET CIRCUIT

When no tape is threaded on the deck, the safety switch is set to OFF. This condition is the same as when the STOP button is pressed, whereby the deck is placed in a non-operating status. In the following description, it is assumed that a tape is threaded and the safety switch is set to ON. When the POWER switch is turned on, noise suppressing capacitors C512 to C516 of the U502's operating input circuits are charged by current applied from U502, causing

the terminals to change to a HIGH state. Approximately 20 milliseconds are required for the PLAY, PAUSE, F.FWD, REW and REC input terminals to change to a HIGH state after the deck has been turned on, while approximately 100 milliseconds are required for the STOP terminal to change to a HIGH state, due to C517's higher capacitance.

Therefore, the U502 memory (flip-flop) is reset and the STOP mode is activated approximately 100 milliseconds after power is applied. U502 becomes active when the STOP terminal is placed in a HIGH state.

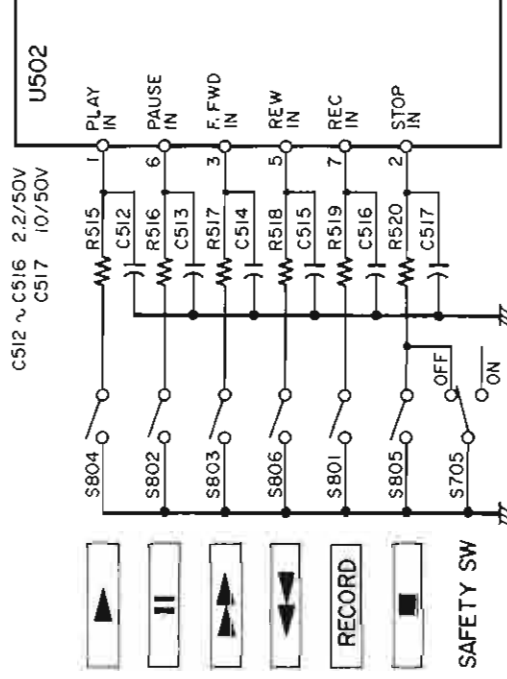

Fig. 6-2 Initial reset circuit

6-3 CAPSTAN MOTOR CIRCUIT

Q505 is cut off when the safety switch stays in the OFF position. Consequently, no capstan motor revolution is available because no power is supplied to the capstan servo control circuit. Q505 is conductive when the safety switch stays in the ON position. Then, the capstan servo control circuit goes on and the capstan motor turns the capstan.

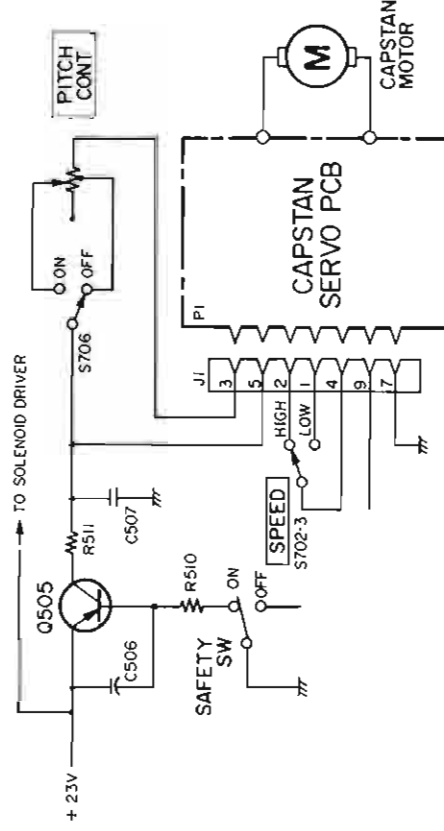

Fig. 6-3 Capstan motor circuit

6-4 POWER MUTING CIRCUIT

The power muting circuit prevents any noise at the OUTPUT terminals or the PHONES jack when the deck is powered on or off.

6-4-1 POWER ON MUTE

When the deck is powered on, the output of 6 V AC is developed across the secondary winding of the power transformer, T701, between its BLU-BLU terminals. This voltage is half-wave rectified on D501, smoothed on C501, and applied to charge C502 by way of R502. When C502 is charged to its charging potential of approximately 1.4V, D503 gains its conductivity and Q501 turns conductive with K433 and K434 relays put to their activity. Closed contacts in K433 and K434 will cause the output circuit of the output amplifier to gain its connection to the output terminal and the phone amplifier. A delay time of approximately 5 seconds is needed before the relay is actuated after the deck has been powered on.

6-4-2 POWER OFF MUTE

Immediately after the deck is switched off, Q501, K433 and K434 are turned off since C501 and C502 are quickly discharged by respective way of direct route and D502 to the meter lighting circuit. Consequently, noise transmission due to transients on power disconnection can be prevented since the output terminal and the phone amplifier are disconnected from the output amplifier.

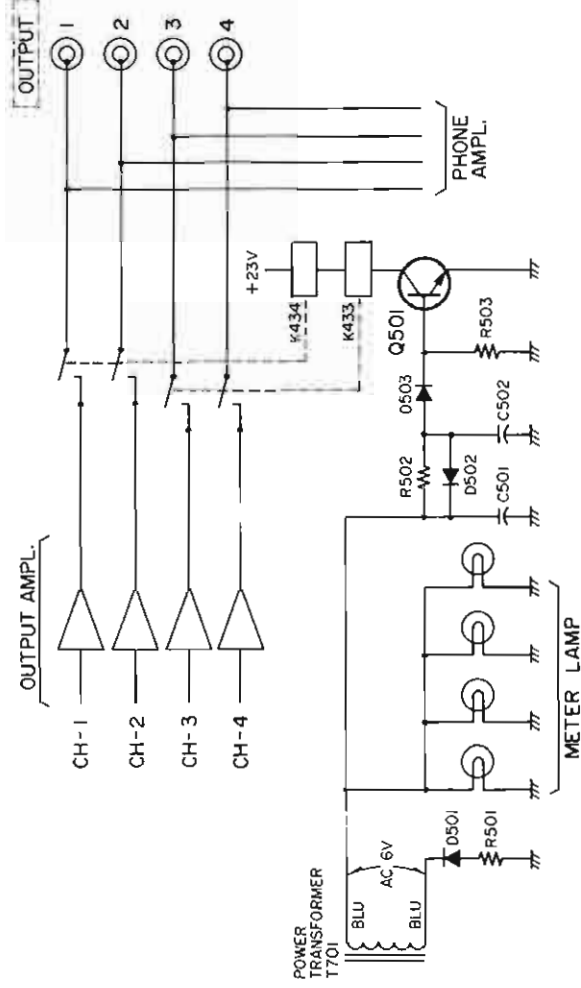

Fig. 6-4 Power muting circuit

6-5 DECK MODES

This item describes the outline on how the control circuit works in any particular mode of the deck. Further descriptions will be made in and after item 6-6 on detailed performances with such driver circuits as relays, reel motors, solenoids, LEDs and other related components.

6-5-1 PLAY MODE

When the deck is put in play mode, H-levelled output signals are available from pin 12, or play out, on U502.

- The voltage required for the status of PLAY is applied to the reel motor by turning the PLAY relay, K501, to the ON position.
- Momentarily-activated K502 aids in driving the right reel motor by applying a higher voltage for a brief period.
- The activated brake solenoid releases brakes from the right and left reel tables and, at the same time, activates the flashing circuit to ensure a switch-over of supply voltages to the brake and capstan solenoids.
- The activated capstan solenoid ensures secure contact of the pinch roller with the capstan.

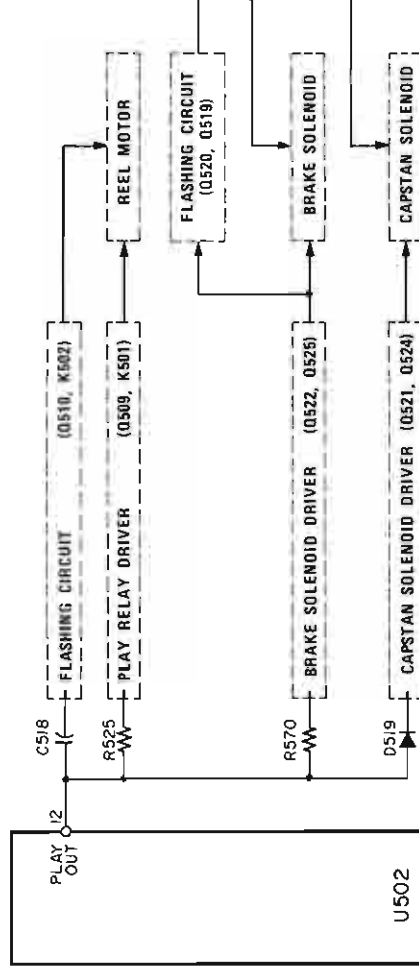

Fig. 6-5 PLAY mode

6-5-2 REC/PLAY MODE

In REC/PLAY mode, H-level signals are available from both pins of 12 (PLAY OUT) and 10 (REC OUT). PLAY OUT signals drive the tape in movement with the deck put in PLAY mode.

The following activities are available from the REC OUT signal.

- The RECORD LED (D801 RED) is illuminated.
- Both Q513 and Q514 are conductive, resulting in H-level record signal transmission to the amplifier section. Record signal functions are described in the item on the amplifier section.

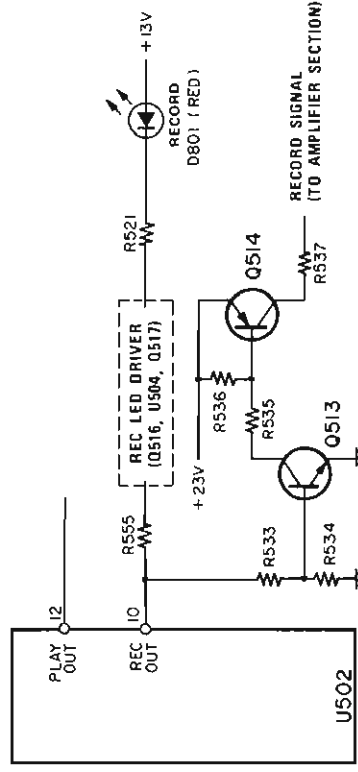

Fig. 6-6 REC/PLAY mode

6-5-3 PAUSE MODE

The H-level is available at pin 11, PAUSE OUT, on U502 only, when the PAUSE button is depressed in STOP or PLAY mode. The status of the deck in this situation is equivalent to that in STOP mode. The PAUSE LED, or D802 green, is not illuminated. The H-level is available at both pins 11 and 12 on U502. When both RECORD and PAUSE buttons are simultaneously depressed in STOP mode, or when the PAUSE button is depressed in REC/PLAY mode. The output from pin 10 on U502 not only illuminates the RECORD LED and transmits the RECORD signal to the amplifier section as described in previous items, but also provides H-level signals to pin 12 on U504. In this situation, since the pin 11 on U502 stays at H-level, Q518 turns conductive and the PAUSE LED is illuminated with pin 11 on U504 and pin 8 on U504 staying on L- and H-levels, respectively. This status is the REC/PAUSE mode.

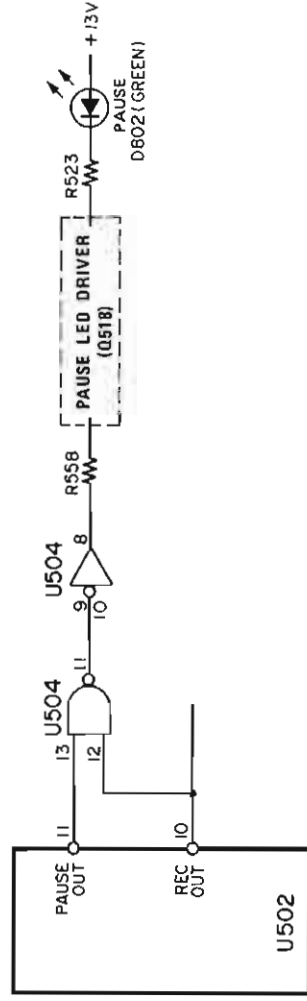

Fig. 6-7 REC/PAUSE mode

6-5-4 FAST MODE

Both F.FWD and REW modes are called FAST mode. H-level output signals are available at pins 14 and 15 on U502 in F.FWD mode, and at pins 13 and 14 in REW mode, respectively. The reel motors are supplied with the proper voltage required in F.FWD or REW mode, with K502 or K503 actuated, depending on the output from pin 15 or 13. The output from the pin 14 releases the brakes from the reel tables with the brake solenoid actuated. The delay circuit shown in Fig. 6-8 is a tape protection circuit in transition from FAST to PLAY or REC/PLAY mode. Performance with this delay circuit are described as follows.

As shown in the figure, U503 is a comparator. An H- or L-level output is available at pin 1 because the minus terminal, pin 2, will have either a lower or higher potential than the plus terminal, pin 3. U503 works as a Schmidt trigger circuit since R546 provides feedback effect from pin 1 to pin 3. Yet, for example, when the deck is working in F.FWD mode, both pins 14 and 15 on U502 are H-levelled. The H-levelled pin 14 on U502 turns Q506 conductive and puts pin 2 on U503 to L-level. Consequently, since pin

1 on U503 is put to H-level with both Q507 and Q508 conductive, muting is applied to both PLAY OUT and REC OUT on U502. Now, if the PLAY button is depressed, F.FWD mode is reset and PLAY mode is stored on U502. Despite the stored PLAY mode, pin 12 on U502 stays on L-level since Q507 is conductive. In the meantime, the reset F.FWD mode, with both pins 15 and 14 on U502 L-levelled, cause the reel motor to stop with the reel tables braked, the same as in STOP mode. Yet, with pin 14 on U502 L-levelled, Q506 is cut off and charging on C525 is initiated by way of +5V, R542 and R543 as sequenced. When the potential at pin 3 on U503 is exceeded by that of the charged C525, or the potential at pin 2 on U503, the output from pin 1 on U503 is inverted from H- to L-level. Consequently, both Q507 and Q508 are cut off. With Q507 cut off, muting is released from pin 12 on U502 and the deck is put in PLAY mode with the PLAY OUT H-levelled. As mentioned above, this delay circuit is designed for suspending the starting of the next mode in transition from FAST to PLAY or REC/PLAY mode until the tape entirely stops, where its delay time is approximately two seconds. Fig. 6-9 illustrates the performance for an example of transition from F. FWD to PLAY mode.

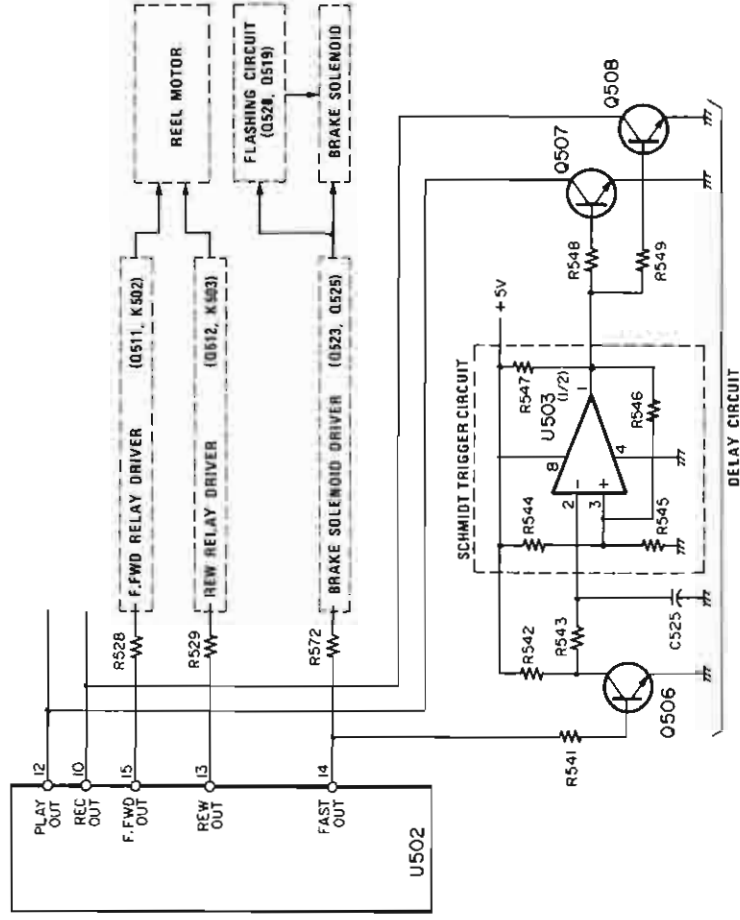

Fig. 6-8 FAST mode

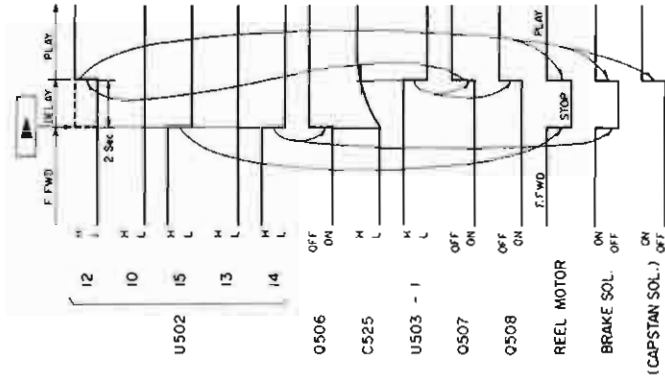

Fig. 6-9 F.FWD→PLAY

6-6 REEL MOTOR DRIVER CIRCUIT

6-6-1 PLAY MODE

In PLAY mode, the H-level output signal is available from pin 12 on U502 with both Q509 and K501 conductive. When K501 is active, its contact point of K501-1 shifts to N.O. side. Then, the right reel motor is directly supplied with 68 V AC, producing take-up torque. The left reel motor is supplied with voltage available from the AC source (approximately 50 V) on proper adjustment by means of R701.

At the point of a rising edge in PLAY mode, Q510 and K502 are conductive for about 100 milliseconds immediately after the status of pin 12 on U502 is inverted from L- to H-level. When K502 continues its conductivity, its contact point of K502-1 shifts to N.O. side so as to supply the right reel motor at the initial stage of PLAY mode and prevents its shutoff due to the loosened tape.

6-6-2 F.FWD MODE

In F.FWD mode, H-level output signals can be obtained from pin 15 on U502 with Q511 and K502 conductive, while the contact of K502-1 on K502 shifts to N.O. side. At this moment, the right reel motor is directly supplied with 100 V AC to develop a high tension winding torque and a high-speed tape winding process sets in. Since the left side reel motor is supplied with approximately 25 V AC by way of R702, a slight back tension torque is available.

6-6-3 REW MODE

In REW mode, pin 13 on U502 is put to H-level with Q512 and K503 conductive. Consequently, the left reel motor is directly supplied with 100 V AC, while the right reel motor is provided with a lower voltage through R702.

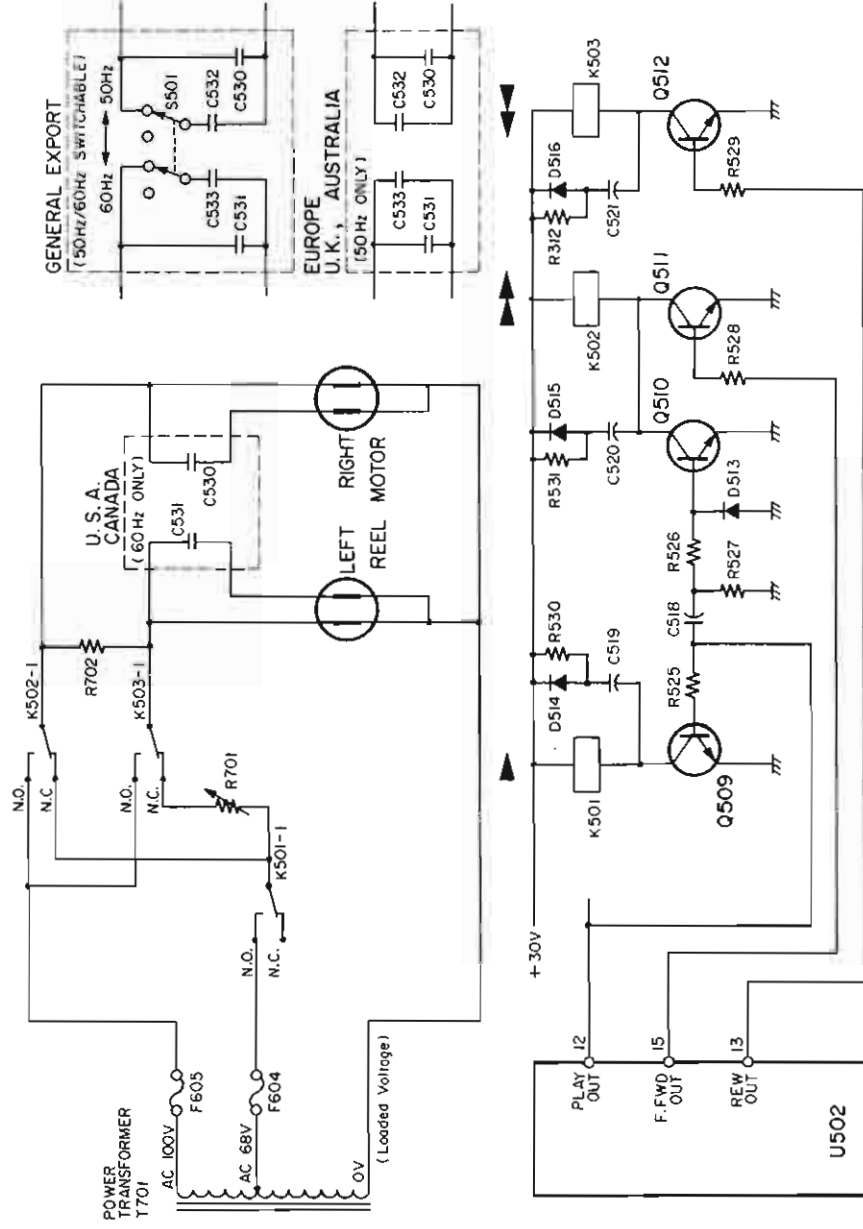

Fig. 6-10 Reel motors driver circuit

6-7 SOLENOID DRIVER CIRCUIT

A pair of the capstan and brake solenoids are employed in the 22-4.

Capstan solenoid

The tape should be set closely to the head with the lifter held up. The tape should set in motion with the pinch roller pressed against the capstan.

Brake solenoid

The brakes on both right and left reel tables should be released.

6-7-1 CAPSTAN SOLENOID DRIVER

The capstan solenoid can be conductive in PLAY mode only.

In PLAY mode, pin 12 of U502 goes HIGH, sending current to Q521 via D519 and R566, turning Q521 on. Consequently, Q524 turns conductive with the capstan solenoid also activated.

6-7-2 BRAKE SOLENOID DRIVER

The brake solenoid is actuated in both PLAY and FAST, F.FWD or REW modes. In PLAY mode, Q522 turns conductive due to the current from pin 12 on U502, while, in FAST mode, Q502 turns conductive due to the current from pin 14 on U502. As Q522, or Q523, turns conductive, Q525 turns conductive with the brake solenoid also actuated.

6-7-3 FLASHING CIRCUIT

In STOP mode, Q519 to Q525 are cut off.

In PLAY or FAST mode, when Q525 turns conductive, the base current of Q520, i.e., the charging current on C528, flows from the source of +30V through the emitter to the base of Q520, R562, C528, and the collector to the emitter of Q525 in the abovementioned sequential order, resulting in supported conductivity of Q520 for approximately 100 msec. until C528 is charged up. As long as Q520 is conductive, Q519 also turns conductive and the solenoid is supplied with +30 V. When Q520 turns non-conductive after C528 is charged up, Q519 also turns non-conductive, where the solenoid is retained with the power available through D517 from the source of +13 V. The abovementioned combination of the higher voltage impressed on the solenoid at its initial stage of operation and the reduced potential applied in its holding is aimed at solenoid heating prevention.

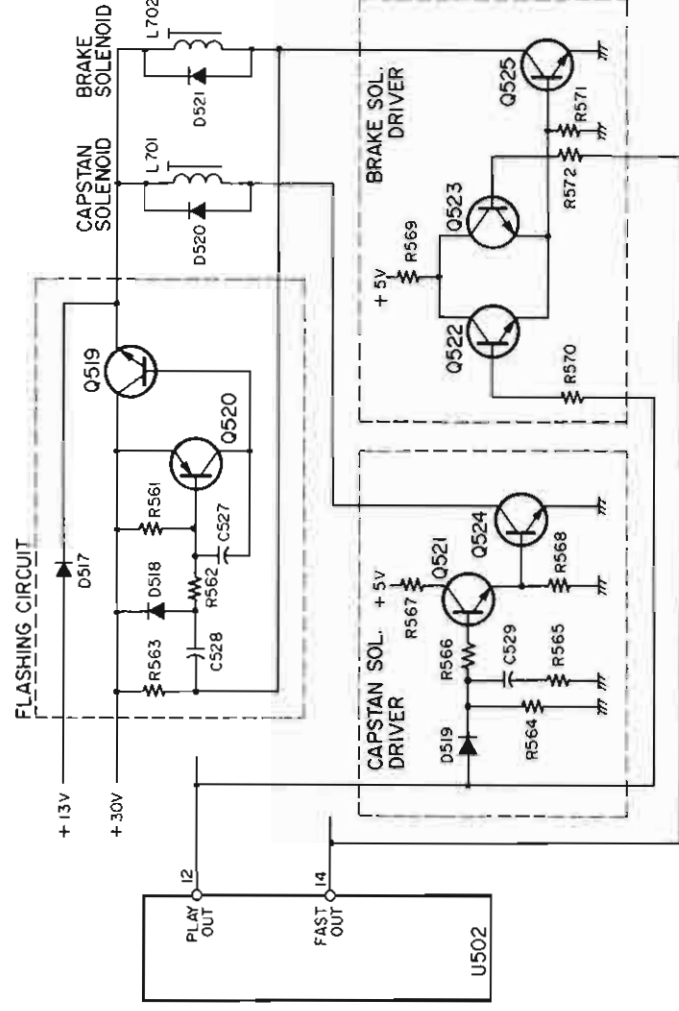

Fig. 6-11 Solenoid driver circuit

6-8 LED DRIVER CIRCUIT

6-8-1 RECORD LED

When all function switches of S432b to S435b are turned off, or opened, Q403 and Q515 turn nonconductive and conductive, respectively. As long as Q515 is nonconductive, both pin 9 on U502 and pin 2 on U504 are retained at L-level.

When pin 9, or AR, on U502 is held L, RECORD mode is disabled. Pin 3 on U504 is locked H when pin 2 is L. If any one of the function switches of S432b to S435b is conducting, pin 9 on U502 and pin 2 on U504 go H, with Q403 and Q515 conductive and cut off, respectively.

Meanwhile, U503 and its peripheral circuits comprise a square wave oscillator of approximately 1 second in period, from which alternating of H- and L-level signals are continuously available. Therefore, when pin 2 on U504 is H, an inverted oscillator output signal of L- and H-levels is available from pin 3 on U504.

When 22-4 is in any mode other than REC/PLAY or REC/PAUSE, pin 10 on U502 goes L with Q516 cut off and pin 5 on U504 goes HIGH.

Assuming the abovementioned status, when pin 4 on U504 is provided with an alternative signal of L- and H-levels, the RECORD LED flashes with Q517 alternatively turned conductive and cut off by means of the alternative output signals of H- and L-levels, or the inverted input signal, available from pin 6 on U504.

When 22-4 is put in REC/PLAY or REC/PAUSE mode, pin 10 on U502 turns H-levelled with Q516 conductive. Therefore, pin 5 on U504 and pin 6 on U504 are locked to L- and H-levels, respectively, with Q517 conductive, resulting in continued illumination of the RECORD LED.

6-8-2 PAUSE LED

When 22-4 is put in the REC/PAUSE mode, H-level appears at pin 11 on U502, or pin 13 on U504, and pin 10 on U502, or pin 12 on U504. Consequently, L- and H-levels appear at pin 11 and pin 8 on U504, respectively, with Q518 conductive, resulting in illuminated PAUSE LED.

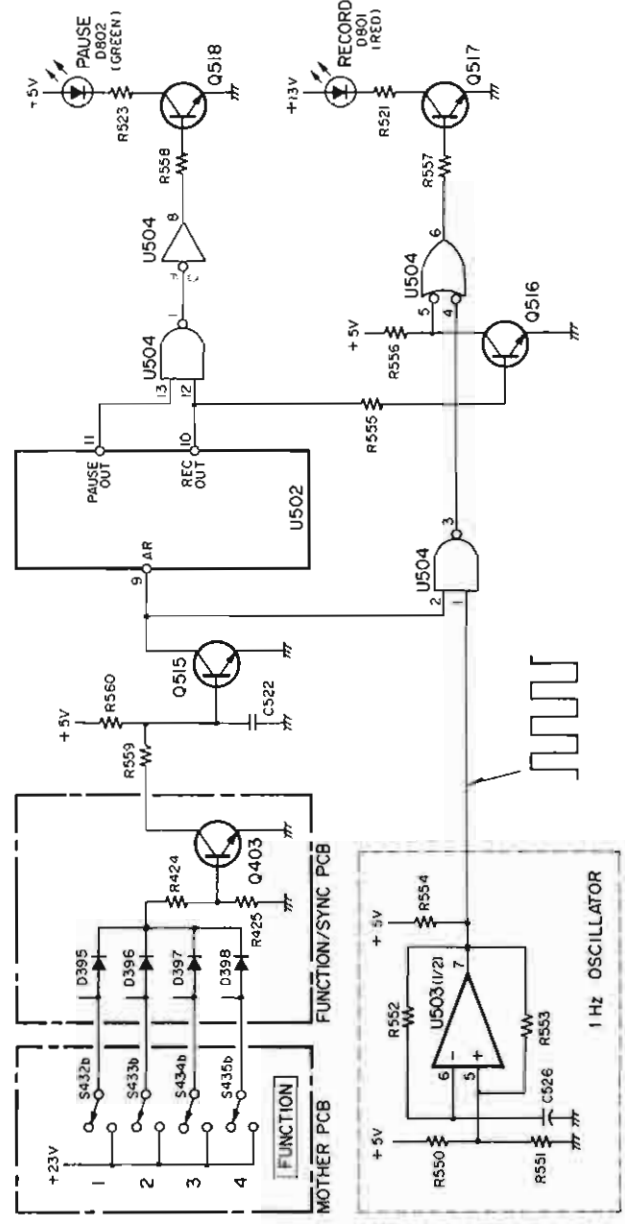

Fig. 6-12 LED driver circuit

6-9 MEMORY CIRCUIT

In REW mode, when pin 4, i.e., the MEMO input terminal on U502 is set at L-level, the deck is put into STOP mode with the REW mode reset.

Counter switch S704 closes the circuit with 900 to 999 indicated on the index counter. When REW mode is specified on the deck with the MEMORY switch turned on, S704 is switched on at the moment where the counter indication arrives at 999 subsequent to 000 as the tape is rewound. Consequently, a momentary L-level appears at the MEMO input terminal via the sequenced route of R539, C524, S703, S704, and GND with the REW mode reset.

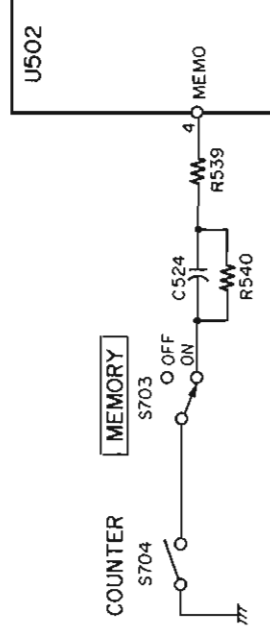

Fig. 6-13 MEMORY circuit

7 AMPLIFIER CIRCUIT DESCRIPTION

Four subsystems are included in RECORD, PLAY and MONITOR systems with the bias oscillator, function relay, and PHONES amplifier circuits excluded. Amplifiers in these systems are designed with particular emphasis on dynamic ranges in consideration of their probable connection to a dbx unit. Furthermore, since a simultaneous synchronization function is provided in 22-4, each channel is furnished with its separate SYNC amplifier which is useful when the recording head is used as a monitoring head. The following descriptions on the amplifier system are mainly related to channel 1.

7-1 PLAYBACK SYSTEM

7-1-1 PLAY EQ AMPLIFIER

This amplifier consists of Q101 to Q103. Since its initial stage includes a bootstrap circuit when the emitter-to-base positive feedback is available through the use of C104 and R105, Q101 presents a high input impedance of approximately $4.5 M\Omega$, or higher, at 1 kHz. Since the amplifier presents such a high input impedance, any resistance value can be selected as an optimal load on the PLAY head. R101 is the loading resistance on the PLAY head with its value selected about ten times as high as that of the head impedance at 20 kHz. The PLAY equalizer amp. is a direct-coupled amplifier in three stages where a double-staged amplifier with Q101 and Q102 is supplemented by an emitter-follower with Q103. Transistors Q101 and Q102 are NPN- and PNP-types, respectively. In this circuit design, the dynamic range and distortion properties are advantageous since higher collector-emitter voltages can be selected for initial stage transistors in particular. Furthermore, since the additional emitter-follower allows a selected higher resistance for loading Q102, a larger open loop gain is available from the amplifier consisting of Q101 and Q102. At the same time, any variation in amplifier open loop gains due to variation in negative feedback circuit impedance can be entirely prevented. The abovementioned features are useful for stability in high frequency range performance with amplifiers. Both transistors Q104 and Q105 are aimed at switching the negative feedback circuit where the high and low speed equalizers are switched over through the use of Q104 and Q105, respectively. Q104 and Q105 are furnished with their base circuits consisting of D101, D102, R118 to R126, C112, and C113, each of which is selected so that smoother transistor switching and minimum click noise may be ensured.

7-1-2 PLAY LINE AMPLIFIER

This amplifier consists of the U101-1/2 operational amplifier. This amplifier is aimed at amplifying any output from the PLAY EQ AMP up to the dbx use level of -10 dB. Since the amplifier gain roughly depends on the ratio of R144 to R142 + R143 together, the gain can be varied on

R143 to obtain the adjustable output level. The parallel resonance circuit on L101 and C119 is designed as a bias trap. The maximum impedance is available from this LC resonance circuit at 100 kHz with the amplifier gain reduced because of its large degree of negative feedback applied.

7-1-3 OUTPUT AMPLIFIER

This amplifier consists of the U101-2/2 operational amplifier. This amplifier is aimed at amplifying any signal attenuated on the OUTPUT control up to the nominal output level of -10 dB.

7-2 MONITOR SYSTEM

7-2-1 METER AMPLIFIER

This amplifier consists of Q111 and Q112. Since the meter amplifier input is connected to the input side of the OUTPUT control, no interlocking can be anticipated on the latter. A double-staged amplifier with a combined pair of NPN and PNP transistors is also employed in this amplifier so as to establish a higher performance efficiency within the limits of the specified source voltage.

7-2-2 PHONES AMPLIFIER

Q241 is a mixing amplifier on CH1 to CH4, with another function as a buffer to the PHONES amplifier. Q242 to Q244 comprise a complementary push-pull amplifier. This circuit can properly drive any low-impedance headphones.

7-2-3 SYNC AMPLIFIER

The SYNC amplifier consists of the U301-1/2 SYNC equalizer amplifier and U301-2/2 SYNC line amplifier. Both amplifiers are designed for any head output amplification in simultaneous SYNC where the recording head is used for monitoring. Since the tone, or frequency response, is not so important in any SYNC amplifier, the equalizer is fixed with no tape speed selection needed. Q301 and Q305 comprise a muting circuit. When any channel in SIMUL SYNC monitoring is set to RECORD mode, muting is available on the SYNC AMPL. with Q301 and Q305 conductive. Furthermore, since SYNC signals do not take any route via the terminal to the dbx unit, encoded signals are monitored for any tapes recorded on the dbx system.

7-3 RECORD SYSTEM

7-3-1 LINE AMPLIFIER

This amplifier consists of the U102-1/2 operational amplifier. This amplifier is aimed at amplifying any line input attenuated on the INPUT control up to the dbx level of -10 dB. R194 and C147 are aimed at amplifier gain control and high frequency range phase correction, respectively.

7-3-2 REC AMPLIFIER

This amplifier consists of U102-2/2 and drives the record head by supplying it with signal currents. Q123 or Q122 turns conductive depending on high or low speed operation with recording compensation properties available from the resonance circuit of L102 and C154, or L102 and C153. R218 is inserted with a view to providing a higher output impedance, or the source impedance, measured from the head side, so that the record head can be driven with a constant current basis. The parallel resonance circuit of L103 and C157 is a bias trap.

7-3-3 BIAS OSCILLATOR CIRCUIT

Switching transistors Q271 and Q272 are aimed at controlling both rising and falling edge performance in bias oscillator starts and stops. The oscillator consists of Q273, Q274, L271 and their peripheral circuits. The RECORD signal at H-level is sent to terminal J469-9 from the CONTROL PCB, turning Q272 ON after approximately 40 msec. of delay due to C271. Approximately 50 msec. is needed from when Q272 becomes ON to when bias rises. It takes about 120 msec. to obtain a complete bias shutdown after any RECORD signal has shifted to L-level.

7-4 SIGNAL CONTROL CIRCUIT

This item describes the function relay circuit for monitor circuit selection and REC relay circuit for record head selection in REC mode. Both circuits are designed with particular emphasis on their performance timing to ensure recording with click noises of the lowest possible level. In the first place, descriptions are made on audio signal selection through the use of contact point circuits on both function and REC relays, and next on the performance of individual relay driver circuits and their related peripheral circuits.

7-4-1 AUDIO SIGNAL CIRCUIT

Reference is to be made on Fig. 7-1 in which channel 1 is illustrated. Fig. 7-1 shows FUNCTION SELECT switches and REC relays separately furnished on individual channels. Output selector switches and function relays are interlocked on CH1 to CH4. Function relays are actuated when the deck is working in REC/PLAY or REC/PAUSE mode with function selector switch conductivity available on at least one channel of CH1 to CH4. Contact points on

function relays are actuated as follows when the OUTPUT selector switch is turned to its SYNC position.

- SOURCE signals can be monitored for any channels on which FUNCTION SELECT switches are turned on.
- Synchronization signals can be monitored for any channels on which function selector switches are turned off.

REC relays are actuated when the deck is put in REC/PLAY or REC/PAUSE mode, for only those channels on which FUNCTION SELECT switches are turned on. Yet, neither REC/PLAY nor REC/PAUSE mode is available on the deck so long as all FUNCTION SELECT switches are turned off for CH1 to CH4. The contact point of K381-a on the REC relay assures that the recording head shifts from SYNC. AMPL. input to REC AMPL. output. The contact point of K381-b ensures that the bias oscillator output shifts from the dummy coil to the erase head. The dummy coil is the same as the erase head in impedance, and aimed at non valuable loading on the bias oscillator to prevent bias output variation.

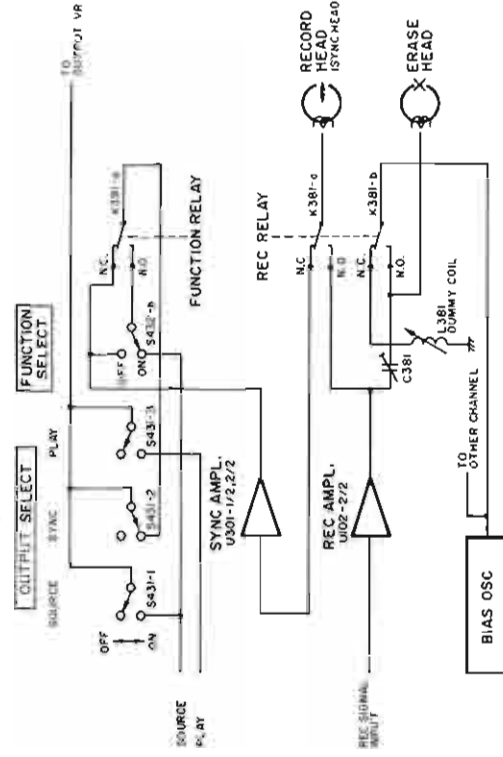

Fig. 7-1 Signal shifting circuit

7-4-2 RELAY DRIVER CIRCUIT

Reference is to be made on Fig. 7-2 and Fig. 7-3.

(1) RECORDING STAND-BY

When any FUNCTION SELECT switch is turned on with the deck in STOP mode, LEDs on selected channels are illuminated (Route ①). At the same time, the base current of Q395 flows in Route ② with Q395 put in stand-by position. (Since Q391 is cut off, no collector current flows on Q395.)

When FUNCTION SELECT switch conductivity is obtained on at least one channel of CH1 to CH4, the base current of Q403 flows in Route ③ with Q403 conductive. Therefore, the low level REC MODE signal is supplied to the CONTROL PCB. (This signal supplies the system control IC with recordable signals with the Q515 cut off on the CONTROL PCB, and causes the RECORD LED to flash. . . See item 6-8-1 and Fig. 6-12.)

(2) RECORDING START

When the deck is put in REC/PLAY or REC/PAUSE mode, the H-level record signal is supplied from the CONTROL PCB. This record signal is supplied to the control circuit in the bias oscillator to initiate its oscillation, and, at the same time, actuates the function relay of K391 with Q400 turned conductive in Route ④. Furthermore, C397 and C398 are charged with the record signal supplied in Routes ⑥ and ⑦. The combined circuits of Q401 and Q402 provide a Schmidt trigger circuit, which is designed for assuring snap action on the output of point C, depending on its alternating levels with reference to some

particular value when the input signal of point A varies slowly. This circuit is aimed at ensuring the almost simultaneous actuation of REC relays on respective channels, even if their operating voltages, or sensitivity indices are not almost identical, while preventing any malfunction due to noise generation. In the meantime, when the potential of approximately 3.5 V is reached at point A in due charging process on C398, Q401 turns conductive with Q402 cut off at the same time, then the current in Route ⑨ flows with Q391 turned conductive. Since Q395 has already been brought into the status of stand-by, Q391 in its conductivity ensures the current flow of ⑩ with the REC relay of K381 actuated. As previously mentioned, the REC relay is aimed at shifting the bias oscillator output from the dummy coil to the erase head besides shifting the record head from SYNC. AMPL. input to REC AMPL. output. It takes about 30 msec. before the REC relay is actuated after the supply of REC signals. This delay time is designed for suspension until monitor circuit disconnection from the SYNC AMPL. output since a higher noise level is anticipated from the SYNC AMPL. when the SYNC AMPL. input is opened on shifting the record head. Furthermore, proper consideration is given to prevent recording any click noises in switching action with the record head since no sufficient rise in bias will be available at the exact moment of record head shifting. When Q391 and Q395 are conductive, or the REC relay is active, L-level SYNC AMPL. muting signals are supplied from the collector of Q391 and muting is active on the SYNC AMPL.

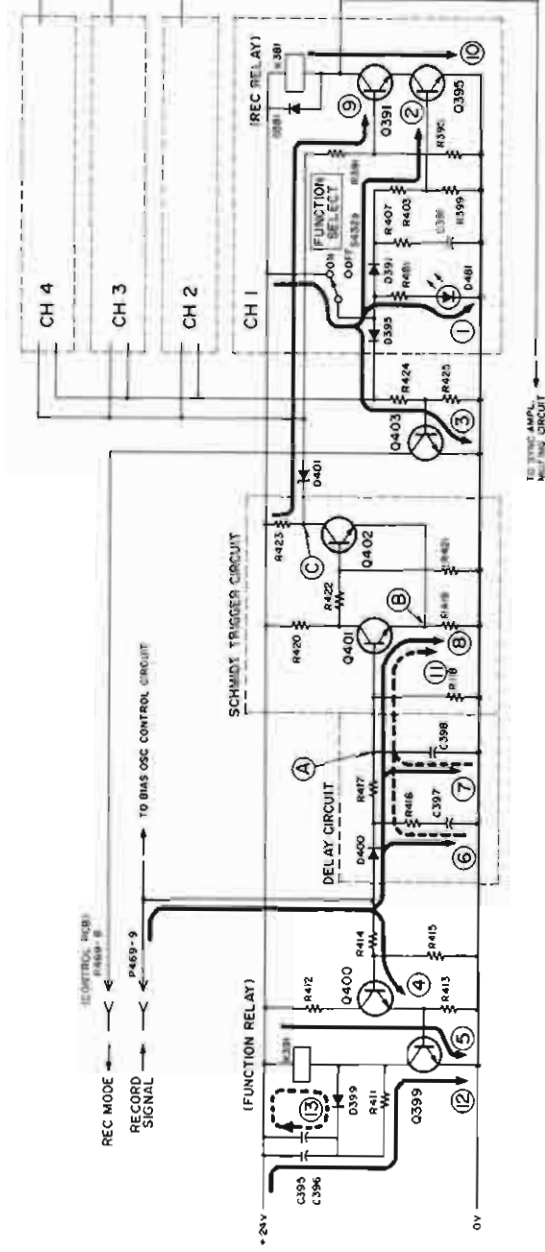

Fig. 7-2 Relay driver circuit

(3) RECORDING STOP

When the FUNCTION SELECT switch is turned off in REC/PLAY or REC/PAUSE mode, REC mode on selected channels is released. With the FUNCTION SELECT switch turned off, the REC relay of K381 is turned off since the current in Route (10) is shut off as Q395 turns non-conductive due to shutdown of the current in Route (2). At the same time, the FUNCTION LED is extinguished due to shutoff of the current in Route (1). When FUNCTION SELECT switches on all channels of CH1 to CH4 are turned off, REC mode signal transmission to the control PCB is suspended since Q403 is cut off. Consequently, Q515 on the control PCB turns conductive with the AR terminal on system control IC put into a L-level, resulting in released REC mode. Therefore, H-level record signals from the control PCB turn L-levelled. Yet, REC mode is also released with record signals L-levelled when the STOP, F.FWD or REW button is depressed in REC/PLAY or REC/PAUSE mode. When any record signal turns L-levelled, the following processes will result.

- The bias oscillator stops with ceased transmission of signals to the bias oscillator control circuit. It takes approximately 120 msec. before completed oscillation.
- With the current in Routes (6), (7), and (8) cut off, a discharging process results in Route (11) from C397 and C398.

When the potential at point (A) falls to approximately 1 V, point (C) is L-levelled with the Schmidt trigger circuit inverted (i.e., Q401 goes OFF and Q402 goes ON). Therefore, the current in Route (9) stops with

Q391 cut off. When the FUNCTION SELECT switch is turned on, the REC relay of K381 turns off immediately after Q391 is cut off. A delay time of approximately 160 msec. is needed before the REC relay is turned off after the record signal has been L-levelled. This delay is aimed at recording no click noise on tapes with the recording head shifted after bias oscillation has stopped.

- Since the current in Route (4) stops, Q400 and Q399 are cut off. As long as Q399 was conductive, C395 and C396 must have been charged with the current in Route (12) to the same potential as the voltage across terminals on the function relay of K391. When Q399 is cut off, a discharging process begins in Route (13) on C396 accumulated in both C395 and C396. K391 is turned off when the gradually decreased discharge current falls to the holding current of K391, or lower. This discharging circuit establishes a delay time of approximately 200 msec. which is aimed at preventing any noise, which is anticipated in SYNC AMPL. input circuit switching, from being supplied to the monitor circuit after the connection of the record head to SYNC AMPL. by means of REC relay.

- In the meantime, when Q391 is cut off, a H-level state is available on its collector, and a muting release signal is supplied to SYNC AMPL. This signal releases muting after approximately 230 msec. of delay caused by C353 in SYNC AMPL. With this delay, muting cannot be released before SYNC AMPL. input circuit transfer is entirely completed, thus click noise transmission to the monitor circuit can be prevented.

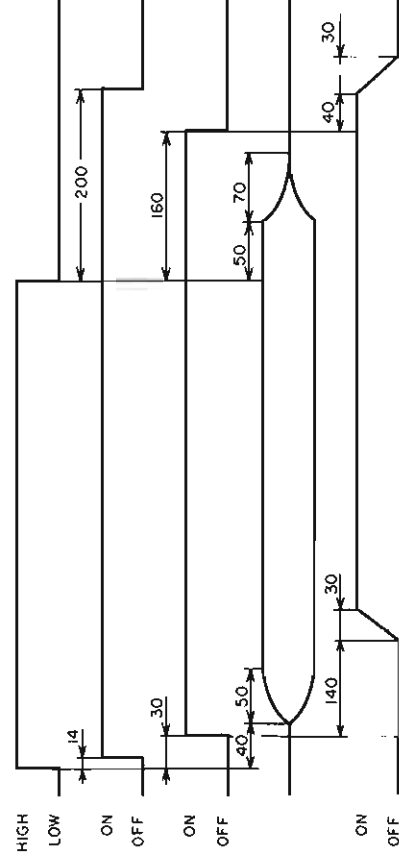

Fig. 7-3 Timing chart on control circuit

SERVICE MANUAL CORRECTION NOTICE FOR 22-4

Please substitute this figure for Fig.7-3 on page 39 for the correct control circuit timing.

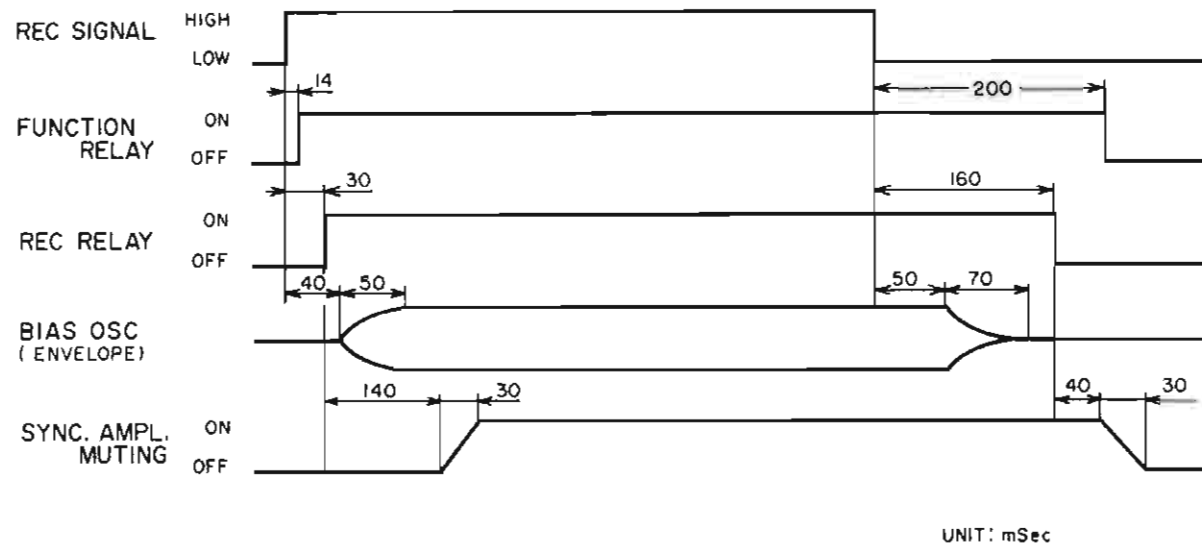
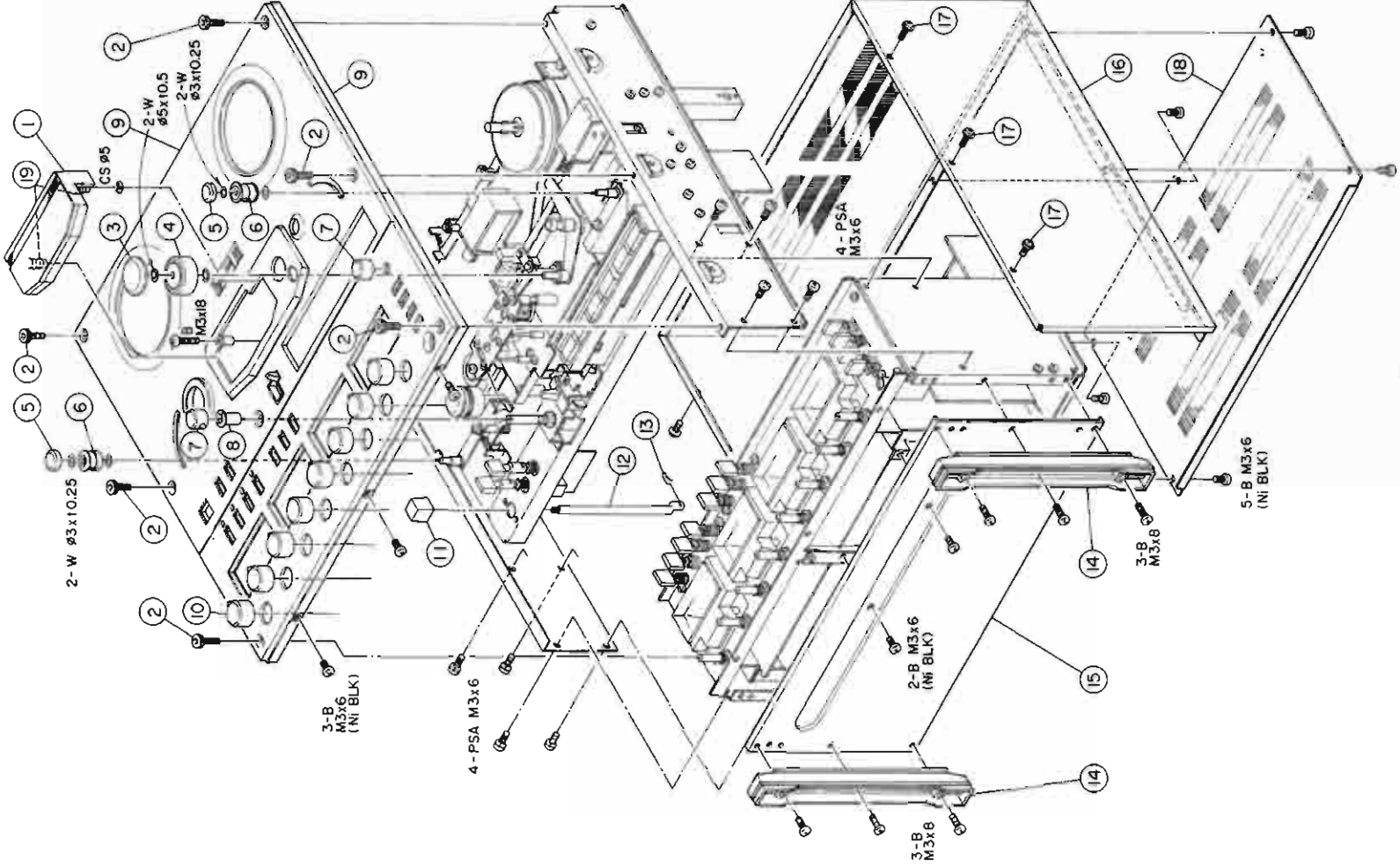

Fig.7-3 Timing chart on control circuit

PARTS LIST SECTION
8 EXPLODED VIEWS AND PARTS LIST
 EXPLODED VIEW - 1



Parts marked with *require longer delivery time.

REF. NO.	PARTS NO.	DESCRIPTION	REMARKS
1 - 1	*5800067001	Housing, Head	
1 - 2	*5581073000	Screw, Front Panel	X-10M
1 - 3	5800066200	Cap. Pinch Roller	
1 - 4	5014175100	Pinch Roller	A2300
1 - 5	*5800066000	Cap. Tension Roller	
1 - 6	5504843000	Roller Assy, Tension	
1 - 7	5534705000	Knob, VR; C	X-10R
1 - 8	*5800066700	Collar Nut	
1 - 9	*5800069100	Panel Assy, Front	
1 - 10	5800080600	Knob, F	X3
1 - 11	5534702000	Button, Power Switch	X-10R
1 - 12	*5534723000	Rod, Power Switch	X-7
1 - 13	*5786360500	R Pin, ϕ 5	
1 - 14	*5533109100	Foot	A6600
1 - 15	*5800079600	Cover Assy, Bottom	
1 - 16	*5800071300	Cover, Top	
1 - 17	*5783114006	Screw, M4 x 6 (BLK Ni)	
1 - 18	*5800070300	Cover, Rear	
1 - 19	*5524292000	Spring, Stud	

INCLUDED ACCESSORIES

REF. NO.	PARTS NO.	DESCRIPTION	REMARKS
	*5128093000	Cord, Input-output Connection	
	*5534267000	Foot, H	A4700RX
	*5085008300	Empty Reel, 7 inch	
	*5062962000	Splicing Tape	
	*5101337100	Open Reel Supplement	U
	*5101708000	Open Reel Supplement	All except U
	*5700007700	22-4 Owner's Manual	U
	*5700007800	22-4 Owner's Manual	All except U

EXPLODED VIEW - 2

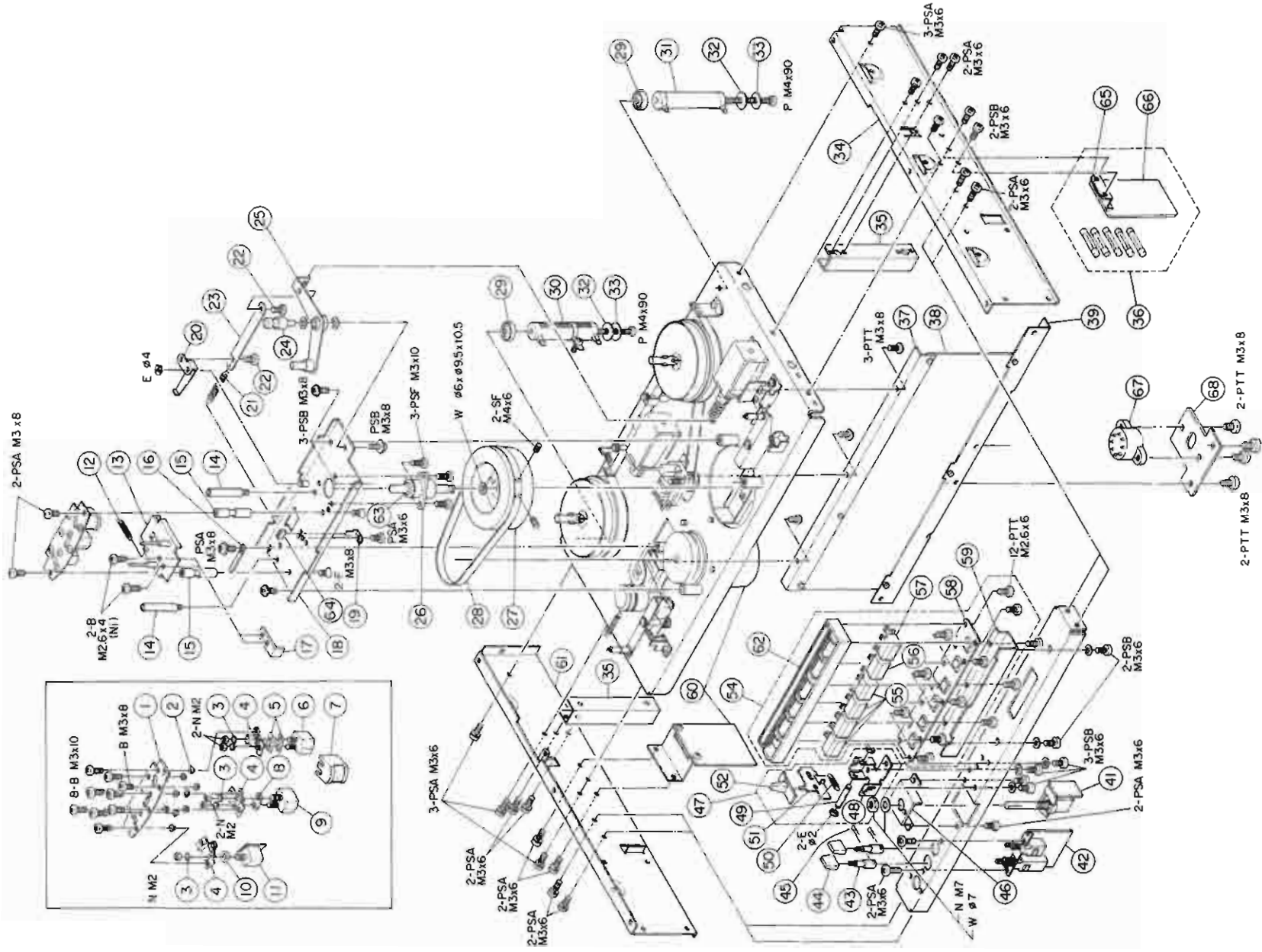

Parts marked with *require longer delivery time.

REF. NO.	PARTS NO.	DESCRIPTION	REMARKS
2 - 1	*5555927000	Plate, Head Base	
2 - 2	*5022050000	Spring, B	
2 - 3	*5785012000	Washer, t 0.4	(A2300)
2 - 4	*5013437100	Bracket, Head	A4300
2 - 5	*5550151100	Spacer, Head; A	A2300SR
2 - 6	5066459000	Head, Playback	A6600
2 - 7	*5554949000	Case, Shield; Head	A2300
2 - 8	*5013439000	Spacer, Record Head	
2 - 9	5066425100	Head, Record	
2 - 10	*5013659100	Spacer, Erase Head	A1340
2 - 11	5066411100	Head, Erase	A3340
2 - 12	*5524287000	Spring, Lifter Return	
2 - 13	*5504836001	Plate Assy, Lifte Base	
2 - 14	*5545190000	Stud, Housing	
2 - 15	*5545181000	Guide, Tape	
2 - 16	*5581038000	Clamper, Cord; A	
2 - 17	*5800067200	Plate, Lifter Base; B	
2 - 18	*5504831000	Plate Assy, Capstan Base	
2 - 19	*5555924000	Stopper, Lifter	
2 - 20	*5555925000	Arm, Joint; A	
2 - 21	*5524288000	Spring, Return	
2 - 22	*5581056000	Screw, Shoulder; A	
2 - 23	*5555926000	Arm, Joint; B	
2 - 24	*5545178000	Pole, Guide	A304
2 - 25	*5504835000	Arm Assy, Pinch Roller	
2 - 26	5504832000	Capstan Assy	
2 - 27	5534849000	Flywheel	
2 - 28	5534468000	Belt, Capstan Drive	A6100
2 - 29	*5534585000	Resistor Base	
2 - 30	*5181581000	Resistor, Nonflammable; 1K Ω	
2 - 31	*5181597000	Resistor, Nonflammable; 250 Ω	
2 - 32	*5785254000	Washer, Bakelite; ϕ 4 x ϕ 15 x t1	
2 - 33	*5785024400	Washer, ϕ 4 x ϕ 15 x +1	
2 - 34	*5800069800	Flame, Side; R	
2 - 35	*5800090800	Holder, Chassis	
2 - 36	*5200012000	PCB Assy, FUSE	GE U, C
	*5200012010	PCB Assy, FUSE	E, UK, A
	*5200012700	PCB Assy, FUSE	
2 - 37	*5800069500	Bracket, CONTROL PCB; A	
2 - 38	*5200011900	PCB Assy, CONTROL	GE U, C
	*5200011910	PCB Assy, CONTROL	E, UK, A
2 - 39	*5200011920	PCB Assy, CONTROL	
2 - 40	*5800069600	Bracket, CONTROL PCB; B	
2 - 41	*5800069900	Chassis, Control	
2 - 42	*5200012300	PCB Assy, VOLUME	
2 - 43	*5200012200	PCB Assy, SPEED SW	
2 - 44	*5534713000	Rod, Joint; C	
2 - 45	5534701000	Button	
2 - 46	*5786360500	R Pin, ϕ 5	
2 - 47	*5800048000	Bracket, VOLUME PCB	
2 - 48	*5600017900	Cue Assy	
2 - 49	*5800066400	Bracket, Cue Assy	
2 - 50	*5800066300	Shaft	
2 - 51	*5800067500	Spring, Slide Plate Return	
2 - 52	*5800067600	Plate, Slide; Cue	
2 - 53	5534703000	Knob, Cue	
2 - 54	*5534850000	Cushion, Stopper	
2 - 55	*5500017800	Button Assy, Operation	
2 - 56	5800069000	Button; C	
2 - 57	5800068900	Button; B	
2 - 58	5800068800	Button; A	
2 - 59	*5200011800	PCB Assy, Operation SW	
2 - 60	*5800068600	Bracket, Button Assy	
	*5370000700	Motor G Assy, DC; Capstan	

(Continued on page 45)

EXPLODED VIEW - 3

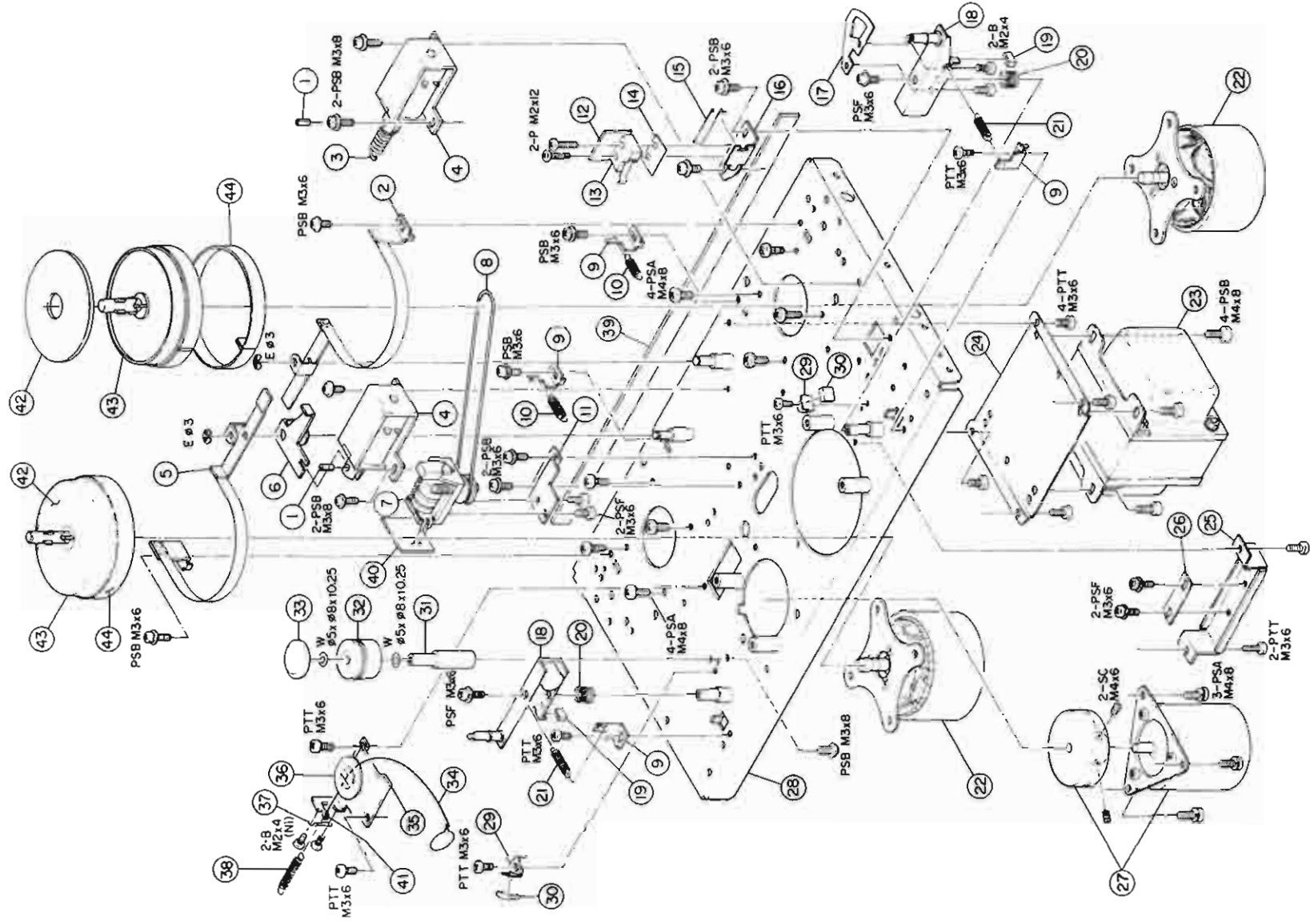

Parts marked with *require longer delivery time.

REF. NO.	PARTS NO.	DESCRIPTION	REMARKS
3 - 1	5786303012	Pin, Stopper	
3 - 2	*5504848000	Band Assy, Brake; B	
3 - 3	*5524286000	Spring, Pressure	
3 - 4	5163048000	Solenoid	
3 - 5	*5504847000	Band Assy, Brake; L	
3 - 6	*5555939000	Lever, Brake Actuating	
3 - 7	5058515000	Counter	A4300
3 - 8	5534853000	Belt, Counter	
3 - 9	*5555929000	Hook, Spring	
3 - 10	*5624291000	Spring, Brake	
3 - 11	*5555940000	Bracket, Counter	
3 - 12	*5210012400	PCB Assy, SW (PCB-104)	
3 - 13	5130003000	Switch, Micro	
3 - 14	*5550025100	Plate, Insulating	A450
3 - 15	*5524290000	Lever, Switch Actuating	
3 - 16	*5555932000	Bracket, Micro Switch	
3 - 17	*5555928000	Cam, Shut Off	
3 - 18	*5504842000	Arm Sub Assy, Tension	
3 - 19	*5534850000	Cushion, Stopper	
3 - 20	*5524106000	Hook Plate, Spring	
3 - 21	*5524289000	Spring, Bias	A6700
3 - 22	7104601001	Motor, AC; Reel	
3 - 23	Δ 5320002300	Transformer, Power	
	Δ 5600017500	Transformer Assy, Power	U, C
	Δ 5600017510	Transformer Assy, Power	GE
3 - 24	*5555919000	Bracket, Transformer	E, UK, A
3 - 25	*5555920000	Angle, Thrust	
3 - 26	*5555921000	Plate, Thrust	
3 - 27	5370000700	Motor G Assy, DC; Capstan	
3 - 28	*5800079701	Chassis Assy, Main	
3 - 29	*5555930000	Stopper, Arm	
3 - 30	*5534851000	Damper, Arm	
3 - 31	*5545182000	Shaft, Guide Roller	
3 - 32	*5504839000	Roller Assy, Guide	
3 - 33	*5800066100	Cap, Roller	
3 - 34	*5788200200	String	
3 - 35	*5800068400	Bracket, Damper Drum	
3 - 36	*5534684000	Drum, Damper	
3 - 37	*5524215000	Stopper, String	
3 - 38	*5800068100	Spring, Damper	
3 - 39	*5555948000	Cushion, Top Cover	
3 - 40	*5210012600	Joint PCB	
3 - 41	*5534130000	Washer, Oil Retaining	
3 - 42	*5800080100	Seat, Reel	
3 - 43	*5504852000	Table Assy, Reel	
3 - 44	*5534852000	Felt, Brake	X-10R X-10R

(Continued from page 43)

REF. NO.	PARTS NO.	DESCRIPTION	REMARKS
2 - 61	*5800069700	Flame, Side; L	
2 - 62	*5800066800	Escutcheon, Button	
2 - 63	*5545175000	Cap, Dust	
2 - 64	*5534850000	Cushion, Stopper	
2 - 65	*5555064000	Clamper, FUSE PCB	
2 - 66	*5210012000	FUSE PCB	J, U, C, GE
	*5210013000	FUSE PCB	E, UK, A
2 - 67	*5131007000	AC Voltage Selector AC 250V 5A	GE
2 - 68	*5800083600	Bracket, AC Voltage Selector	GE

EXPLODED VIEW - 4

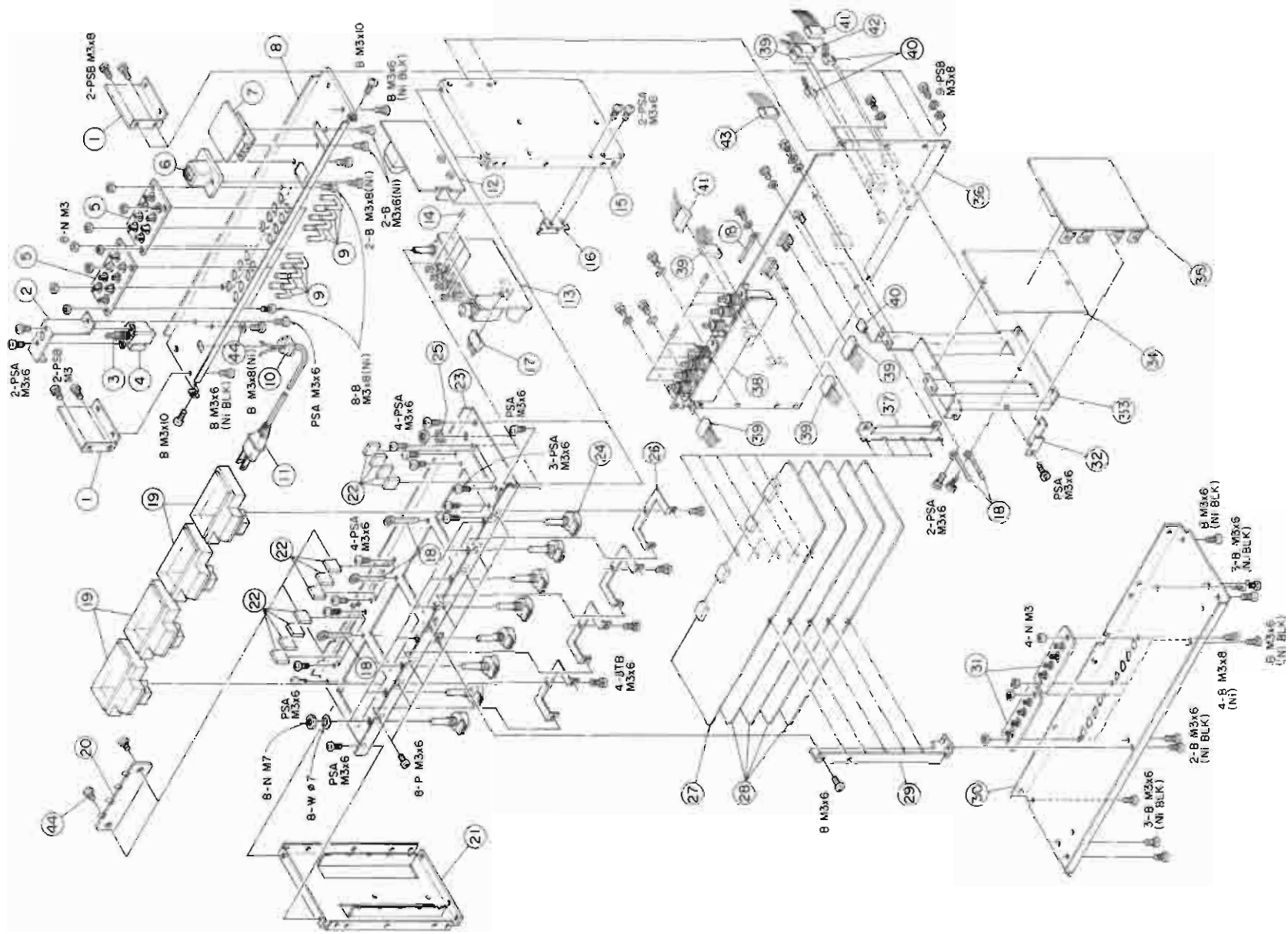

Parts marked with *require longer delivery time.

REF. NO.	PARTS NO.	DESCRIPTION	REMARKS
4 - 1	*5800066600	Angle, Reinforcing	
4 - 2	*5800067400	Bracket, Power Switch	U, C
4 - 3	△ 5300019300	Switch, Push; Power	All except U, C
	△ 5300019400	Switch, Push; Power	U
4 - 4	△ 5052910000	Spark Killer, 0.033 μ F + 120 Ω /125V	C
	△ 5052911000	Spark Killer, 0.033 μ F + 120 Ω /250V	GE
	△ 5292002500	Spark Killer, 0.01 μ F + 300 Ω	E, UK, A
	△ 5267702500	Spark Killer, 0.047 μ F/250V	
4 - 5	*5124053000	Jack, Pin; 8P	
4 - 6	*5122339000	Connector Socket, 6P	
4 - 7	*5200012100	PCB Assy, CONNECTOR	
4 - 8	*5800069300	Chassis, Connector; B	
4 - 9	*5330505000	Plug, Shorting; 2P	
4 - 10	*5534660000	Strain Relief, AC Power Cord	
4 - 11	△ 5128027000	Cord, AC Power	GE
	△ 5128075000	Cord, AC Power	U, C
	△ 5128018000	Cord, AC Power	E
	△ 5128047000	Cord, AC Power	UK
	△ 5350083000	Cord, AC Power	A
4 - 12	*5200011100	PCB Assy, OSC	
4 - 13	*5200011300	PCB Assy, PHONE AMP	
4 - 14	*5786305000	R Pin, ϕ 5	
4 - 15	*5800070600	Flame, Amplifier; R	
4 - 16	*5800067800	Bracket, OSC	
4 - 17	*5122168000	Connector Socket, 6P	
4 - 18	*5581038000	Clamper, Cord; A	
4 - 19	5296001500	Meter, VC	
4 - 20	*5200011600	PCB Assy, LED	
4 - 21	*5800070500	Flame, Amplifier; L	
4 - 22	5800068300	Button	
4 - 23	*5800070100	Chassis, Amplifier	
4 - 24	5282009202	Var. Res., 100 K Ω (B)	
4 - 25	*5800068000	Collar, VR	
4 - 26	*5550176000	Bracket, Meter	
4 - 27	*5200011400	PCB Assy, FUNCTION SYNC	
4 - 28	*5200011000	PCB Assy, REC/PLAY AMP	
4 - 29	*5800067300	Bracket, PCB; B	
4 - 30	*5800069200	Chassis, Connector; A	
4 - 31	*5124052000	Jack, Pin; 4P	
4 - 32	*5550173000	Bracket, BIAS ADJ PCB	
4 - 33	*5800070200	Plate, Shield; A	
4 - 34	*5800067900	Plate, Shield; B	
4 - 35	*5200011200	PCB Assy, BIAS ADJ	
4 - 36	*5200011700	PCB Assy, AMP MOTHER	
4 - 37	*5800066900	Bracket, PCB; A	
4 - 38	*5200011500	PCB Assy, SWITCH	
4 - 39	*5122170000	Connector Socket, 8P	
4 - 40	*5122165000	Connector Socket, 3P	
4 - 41	*5122270000	Connector Socket, 8P (BLK)	
4 - 42	*5122286000	Connector Socket, 8P (RED)	
4 - 43	*5122171000	Connector Socket, 9P	
4 - 44	*55555063000	Washer, GND	

ASSEMBLING HARDWARE CODING LIST



All screws conform to ISO standards, and have crossrecessed heads, unless otherwise noted. ISO screws have the head inscribed with a point as in the figure to the right.

FOR EXAMPLE:



* Inner dia. for washers and nuts

Code	Name	Type	Code	Name	Type		
MACHINE SCREW	R	Round Head Screw	TAPPING SCREW	BTA	Binding Head Tapping Screw(A Type)		
	P	Pan Head Screw		BTB	Binding Head Tapping Screw(B Type)		
	T	Stove Head Screw (Truss)		RTA	Round Head Tapping Screw(A Type)		
	B	Binding Head Screw		RTB	Round Head Tapping Screw(B Type)		
	F	Flat Countersunk Head Screw	SETSCREW	SF	Hex Socket Setscrew(Flat Point)		
	O	Oval Countersunk Head Screw		SC	Hex Socket Setscrew(Cup Point)		
	RW	Round Head Wood Screw		SS	Slotted Socket Setscrew(Flat Point)		
	WOOD SCREW	PTT		Pan Head Tapitite Screw	E	E-Ring (Retaining Washer)	
					W	Flat Washer (Plain)	
	TAPTITE SCREW	WTT		Washer Head Tapitite Screw	SW	Lock Washer (Spring)	
SEMS SCREW			LWI		Lock Washer (Internal Teeth)		
			LWE		Lock Washer (External Teeth)		
			TW		Trim Washer (Countersunk)		
PSA			Pan Head SEMS Screw(A Type)		NUT	N	Hex Nut
PSB			Pan Head SEMS Screw(B Type)				

9 PC BOARDS AND PARTS LIST

PC Boards shown viewed from foil side

REC/PLAY AMPL PCB ASSY

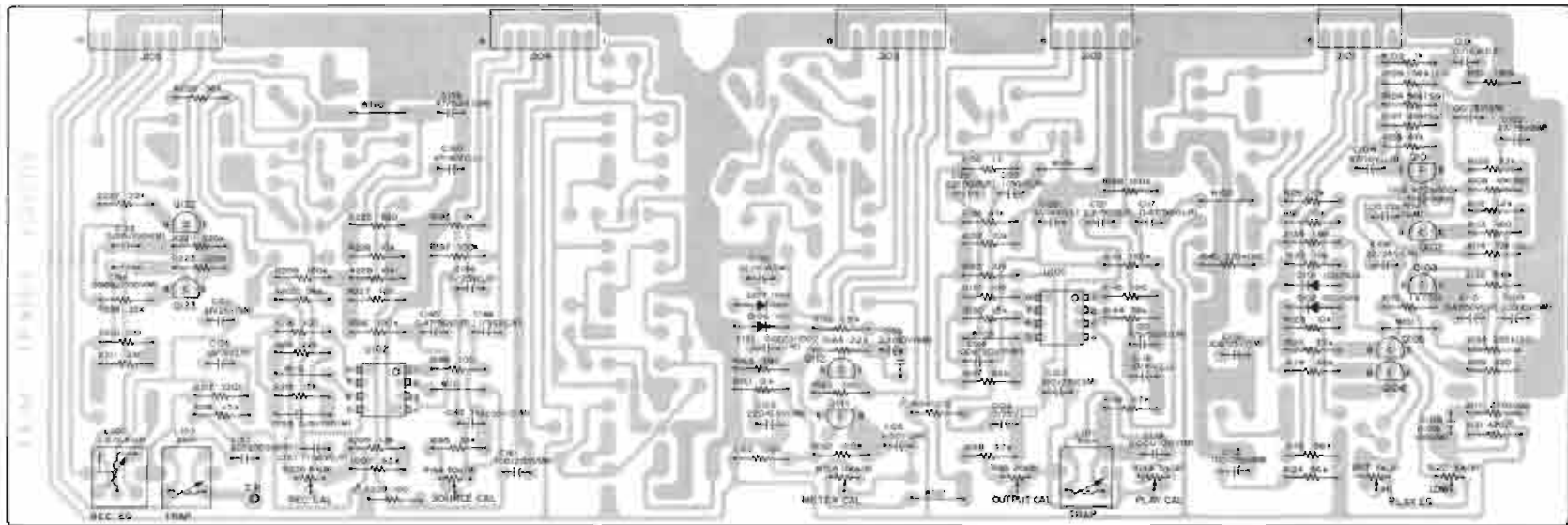

AMP MOTHER PCB ASSY

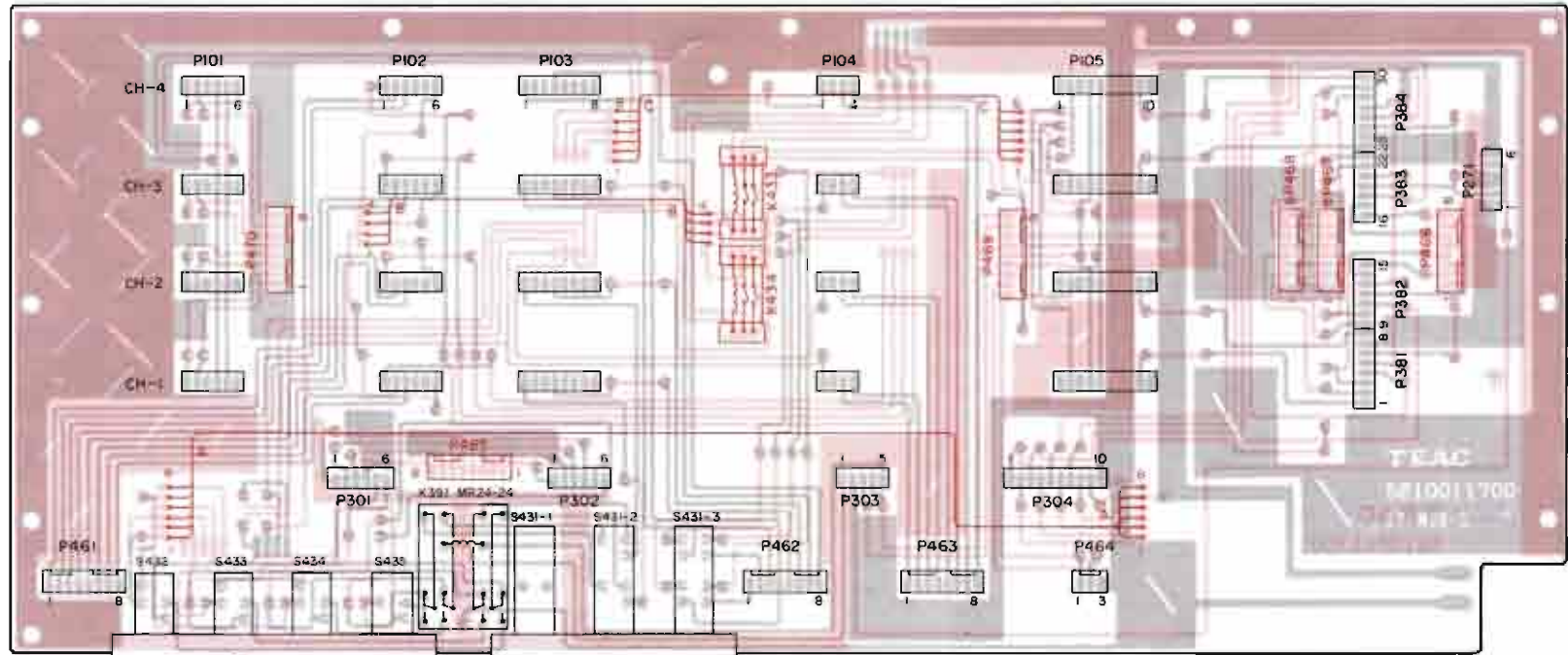

FUNCTION SYNC PCB ASSY

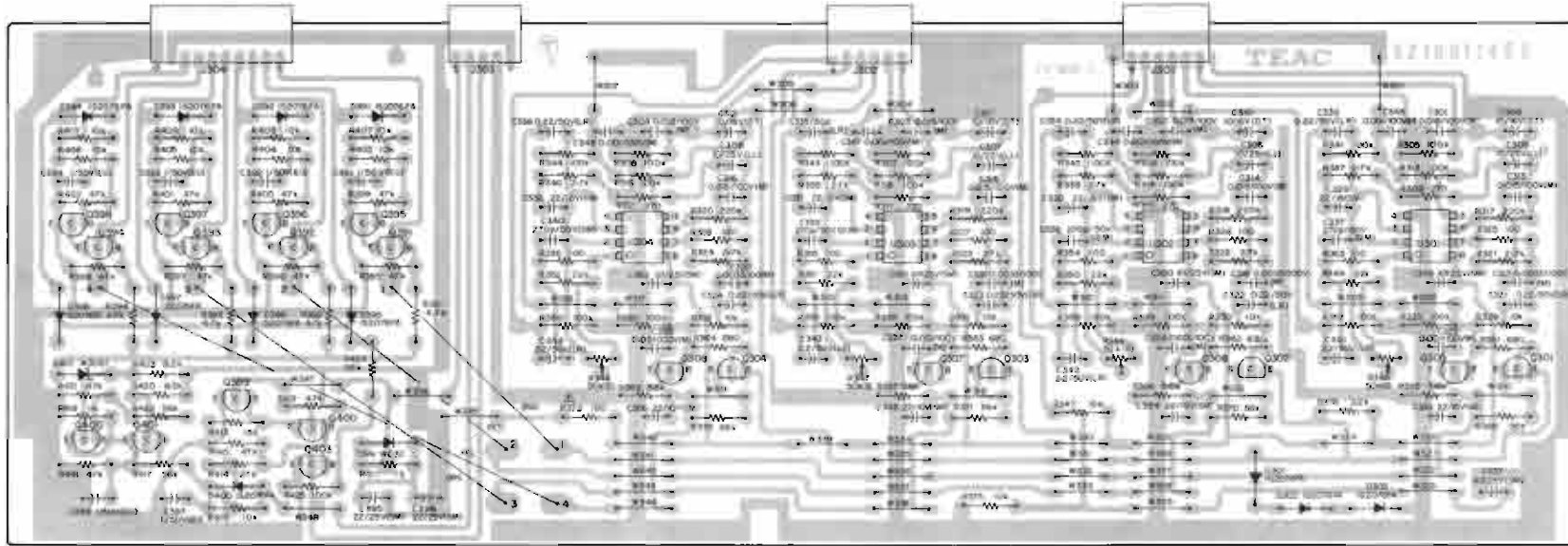

CONTROL PCB ASSY

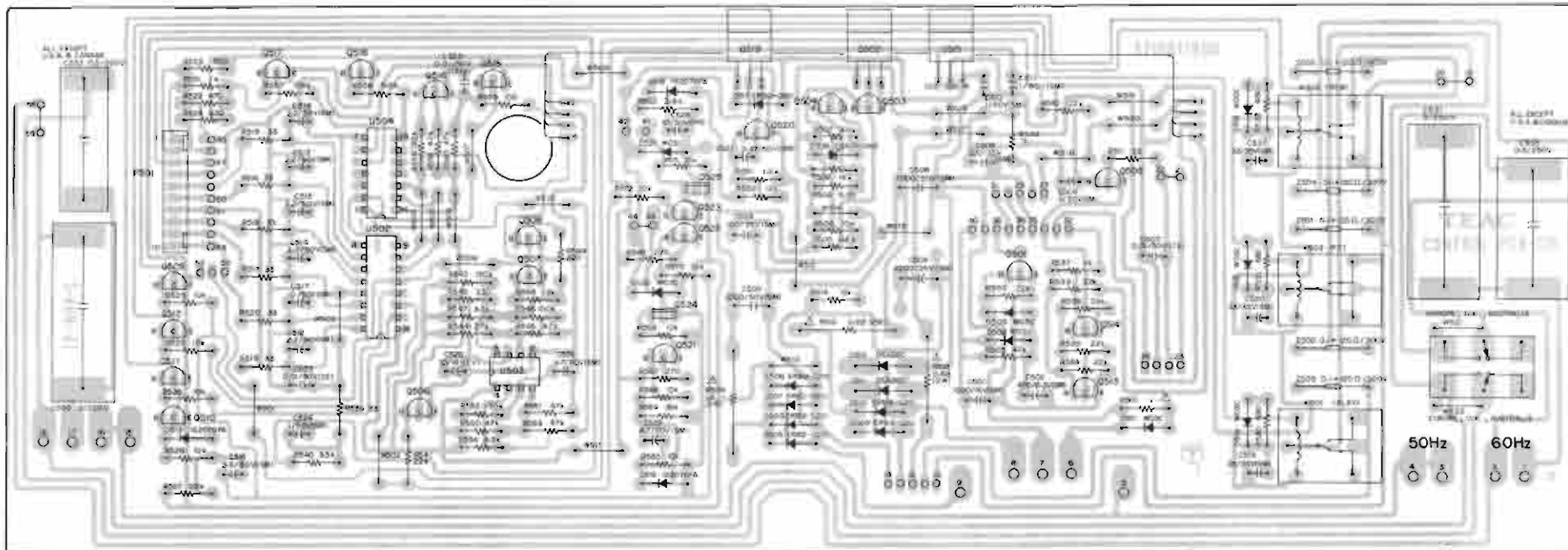

AMP MOTHER PCB ASSY

REF. NO.	PARTS NO.	DESCRIPTION
C152	5173037000	Elec. 47 μ F 25V (SM)
C153	5170429800	Mylar 0.015 μ F 100V
C154	5170423800	Mylar 0.0082 μ F 100V
C155	5170453800	Mylar 0.15 μ F 100V
C156	5171590000	Elec. 10 μ F 16V (LFR)
C157	5173731000	Polypro. 820pF 100V
C159	5173034000	Elec. 47 μ F 6.3V (SM)
C160	5260223110	Elec. 47 μ F 16V (LL)
C161	5173046000	Elec. 100 μ F 25V (SM)
VARIABLE RESISTORS		
R117	5280000802	Semi-fixed 5k Ω (B)
R122	5280000802	Semi-fixed 5k Ω (B)
R143	5280000802	Semi-fixed 5k Ω (B)
R149	5280001102	Semi-fixed 20k Ω (B)
R159	5280001702	Semi-fixed 100k Ω (B)
R194	5280001502	Semi-fixed 50k Ω (B)
R206	5280000802	Semi-fixed 5k Ω (B)
COILS		
L101	5160044000	Trap, 3mH
L102	5160045000	Rec EO, 1.5 ~ 2.4mH
L103	5160044000	Trap, 3mH
MISCELLANEOUS		
J101, J102	5122377000	Connector Socket, 6P
J103, J104	5122379000	Connector Socket, 8P
J105	5122381000	Connector Socket, 10P
	5724042000	Pin, F-3

REF. NO.	PARTS NO.	DESCRIPTION
	5200011700	PCB Assy
	5210011700	PCB
P101, P102	5122358000	Connector Plug, 6P
P103	5122360000	Connector Plug, 8P
P104	5122356000	Connector Plug, 4P
P105	5122362000	Connector Plug, 10P
P271	5122358000	Connector Plug, 6P
P301, P302	5122358000	Connector Plug, 6P
P303	5122357000	Connector Plug, 5P
P304	5122362000	Connector Plug, 10P
P381	5122360000	Connector Plug, 8P
P382, P383	5122359000	Connector Plug, 7P
P384	5122360000	Connector Plug, 8P
P461~P463	5122132000	Connector Plug, 8P (WHT)
P464	5122127000	Connector Plug, 3P (WHT)
P465, P466	5122189000	Connector Plug, 8P (BLK)
P467	5122305000	Connector Plug, 8P (RED)
P468	5122132000	Connector Plug, 8P (WHT)
P469	5122133000	Connector Plug, 9P (WHT)
P470	5122132000	Connector Plug, 8P (WHT)
K391	5290007700	Relay, 12V; MR24-24S
K433, K434	5061137000	Relay, 12V; LAB2L
	5200011500	PCB Assy, SW
	5210011500	PCB
S431	5300018900	Switch, Push; 3-gang 4P
S432	5300019100	Switch, Push; 4-gang DP

[U]: U.S.A.
[A]: AUSTRALIA[C]: CANADA
[E]: EUROPE[GE]: GENERAL EXPORT
[UK]: U.K.

CONTROL PCB ASSY

REF. NO.	PARTS NO.	DESCRIPTION
	5200011900	PCB Assy [GE]
	5200011910	PCB Assy [U, C]
	5200011920	PCB Assy [E, UK, A]
	52100011900	PCB
	IC's	
U501	5220405100	µPC-78M05H
U502	5147047000	M-54410P
U503	5220012500	µPC393C
U504	5147056000	HD-7400P
	TRANSISTORS	
Q501	5042383000	2SC536F
Q502	5145087000	2SD313E
Q503	5230771000	2SC2274KE
Q504	5042383000	2SC536F
Q505	5230013000	2SA984KE
Q506~Q513	5042383000	2SC536F
Q514	5042553000	2SA733P
Q515~Q518	5042383000	2SC536F
Q519	5145087000	2SD313E
Q520	5230013000	2SA984KE
Q521~Q523	5042383000	2SC536F
Q524, Q525	5231755400	2SD794Q
	DIODES	
D501~D503	5143315000	W03C
D504~D507	5143243000	ERB12-02G1
D508	5143153000	Zener, EQA01-06R
D509, D510	5143243000	ERB12-02G1
D511, D512	5224013000	DSA26C
D513	5224012510	1S2076FA
D514~D516	5143315000	W03C
D517	5143243000	ERB12-02G1
D518, D519	5224012510	1S2076FA
D520, D521	5143315000	W03C
	RESISTORS	
All resistors are rated ±5% tolerance, ¼ watt and of carbon type unless otherwise noted.		
R501	5184201000	1Ω Nonflammable
R502	5183122000	47kΩ
R503	5183114000	22kΩ
R504	5184302000	1.5Ω 10% 2W Cement
R505	5183102000	6.8kΩ
R506	5183106000	10kΩ
R507	5183096000	3.9kΩ
R508	518312000	18kΩ
R509	5183102000	6.8kΩ
R510	5183114000	22kΩ
R511	5184233000	22Ω Nonflammable
R512, R513	5184294000	0.68Ω 10% 2W Cement
R514	5183106000	10kΩ
R515~R520	5183046000	33Ω
R521	5183082000	1kΩ
R522	5183074000	470Ω
R523	5183080000	820Ω
R524	5183070000	330Ω
R525, R526	5183106000	10kΩ
R527	5183114000	22kΩ
R528, R529	5183106000	10kΩ
R530~R532	5183078000	680Ω
R533~R536	5183114000	22kΩ
R537, R538	5183082000	1kΩ
R539	5183046000	33Ω

[U]: U.S.A.
[A]: AUSTRALIA

[C]: CANADA
[E]: EUROPE

[GE]: GENERAL EXPORT
[UK]: U.K.

REF. NO.	PARTS NO.	DESCRIPTION
R540	5183118000	33kΩ
R541	5183114000	22kΩ
R542	5183134000	150kΩ
R543	5183070000	330Ω
R544	5183116000	27kΩ
R545	5183122000	47kΩ
R546	5183130000	100kΩ
R547	5183094000	3.3kΩ
R548, R549	5183114000	22kΩ
R550, R551	5183122000	47kΩ
R552	5183134000	150kΩ
R553	5183122000	47kΩ
R554	5183094000	3.3kΩ
R555	5183114000	22kΩ
R556	5183098000	4.7kΩ
R557, R558	5183100000	5.6kΩ
R559	5183058000	100Ω
R560	5183122000	47kΩ
R561	5183084000	1.2kΩ
R562	5183108000	12kΩ
R563	5180096000	3.9kΩ
R564	5183120000	39kΩ
R565, R566	5183106000	10kΩ
R567	5183068000	270Ω
R568	5183068000	270Ω
R569	5183068000	10kΩ
R570~R572	5183106000	10kΩ
	CAPACITORS	
C501	5172970000	1000µF 16V (SM)
C502	5172959000	470µF 6.3V (SM)
C503	5172973000	1000µF 50V (SM)
C504	5172936000	100µF 35V (SM)
C505	5172945000	220µF 35V (SM)
C506	5172882000	1µF 50V (SM)
C507	5054204000	0.01µF 50V 10% Ceramic
C508	5172973000	1000µF 50V (SM)
C509	5172978000	2200µF 25V (SM)
C510, C511	5172882000	1µF 50V (SM)
C512~C516	5172886000	2.2µF 50V (SM)
C517	5172903000	10µF 50V (SM)
C518	5172890000	3.3µF 50V (SM)
C519~C521	5172918000	33µF 35V (SM)
C522, C523	5054204000	0.01µF 50V 10% Ceramic
C524	5172882000	1µF 50V (SM)
C525	5260086200	10µF 16V (EV)
C526	5172896000	4.7µF 50V (SM)
C527	5172880000	0.47µF 50V (SM)
C528	5172903000	10µF 50V (SM)
C529	5172896000	4.7µF 50V (SM)
C520, C531	5171613000	3µF 250V AC Film
C532, C533	5267702700	0.5µF 250V AC Film [All except U, C]
	MISCELLANEOUS	
K501~K503	5061134000	Relay, 24V LC1-N
S501	5044456000	Switch, Slide DPDT [GE]
Z501~Z505	5052905000	Spark Killer, 0.1µF + 120/300V
	5033295000	Tube, Insulating (3 used)
	5033291000	Plate, Insulating (3 used)

BIAS ADJ PCB ASSY

REF. NO.	PARTS NO.	DESCRIPTION
	5200011200	PCB Assy
	5210011200	PCB
DIODES		
D381~D384	5143116000	1SR34200VL
TRIMMER CAPACITORS		
C381~C384	5170325000	10-100pF
COILS		
L381~L384	5160044000	Trap, 3mH
MISCELLANEOUS		
K381~K384	5061128000	Relay, 24V LZN2-1
J381	5122379000	Connector Socket, 8P
J382, J383	5122378000	Connector Socket, 7P
J384	5122379000	Connector Socket, 8P

OSC PCB ASSY

REF. NO.	PARTS NO.	DESCRIPTION
	5200011100	PCB Assy
	5210011100	PCB
TRANSISTORS		
Q271	5145151000	2SC1815GR
Q272	5145082000	2SC2060Q
Q273, Q274	5042445000	2SC1226AR
RESISTORS		
All resistors are rated $\pm 5\%$ tolerance, $\frac{1}{4}$ watt and of carbon type unless otherwise noted.		
R271	5183118000	33k Ω
R272	5183084000	1.2k Ω
R273	5183102000	6.8k Ω
R274	5183118000	33k Ω
R275	5183130000	100k Ω
R276	5183108000	12k Ω
R277	5183090000	2.2k Ω
R278	5183106000	10k Ω
R279	△ 5184225000	10 Ω Nonflammable
R280	5180090000	2.2k Ω $\frac{1}{2}$ W
R281, R282	5180098000	4.7k Ω $\frac{1}{2}$ W
R283	5183058000	100 Ω
R284, R285	5180042000	22 Ω $\frac{1}{2}$ W
CAPACITORS		
C271	5260086510	Elec. 22 μ F 16V (EU)
C272	5173037000	Elec. 47 μ F 25V (SM)
C273	5170413800	Mylar 0.0033 μ F 100V 5%
C274	5170419800	Mylar 0.0056 μ F 100V 5%
C275	5170413800	Mylar 0.0033 μ F 100V 5%
C276	5054404000	Mylar 4200pF 300V 10%
MISCELLANEOUS		
L271	5056323100	OSC Coil
J271	5122377000	Connector Socket, 6P

PHONE AMPL PCB ASSY

REF. NO.	PARTS NO.	DESCRIPTION
	5200011300	PCB Assy
	5210011300	PCB
TRANSISTORS		
Q241, Q242	5145151000	2SC1815GR
Q243	5145082000	2SC2060Q
Q244	5145084000	2SA934Q
DIODES		
D241, D242	5224012510	1S2076FA
RESISTORS		
All resistors are rated $\pm 5\%$ tolerance, $\frac{1}{4}$ watt and of carbon type unless otherwise noted.		
R241~R244	5183130000	100k Ω
R245	5183124000	56k Ω
R246	5183102000	6.8k Ω
R247	5183100000	5.6k Ω
R248	5183064000	180 Ω
R250	5183112000	18k Ω
R251	5183114000	22k Ω
R253	5183090000	2.2k Ω
R254	5183138000	220k Ω
R255, R256	5180034000	10 Ω $\frac{1}{2}$ W
R257	5180032000	8.2 Ω
R258	5183082000	1k Ω
R259	5183122000	47k Ω
CAPACITORS		
C241	5171582000	Elec. 0.33 μ F 50V (LR)
C242, C243	5172992000	Elec. 1 μ F 50V (SM)
C244	5173037000	Elec. 47 μ F 25V (SM)
C245	5054382000	Dip. Mica 22pF 50V 10%
C246	5173073000	Elec. 470 μ F 25V (SM)
C247	5173011000	Elec. 10 μ F 25V (SM)
C248	5054742000	Dip. Mica 47pF 50V 10%
MISCELLANEOUS		
R249	5282008302	Var. Res. 50k Ω (A)
S241	5300019000	Switch, Push; 4-gang
J241	5124046000	Jack, PHONE
J242	5122130000	Connector Plug, 6P

[U]: U.S.A.
[A]: AUSTRALIA[C]: CANADA
[E]: EUROPE[GE]: GENERAL EXPORT
[UK]: U.K.

FUSE PCB ASSY (PC Board omitted)

REF. NO.	PARTS NO.	DESCRIPTION
	5200012010	PCB Assy [U, C]
	5200012700	PCB Assy [E, UK, A]
	5200012000	PCB Assy [GE]
	5210012000	PCB [U, C]
	5210012700	PCB [E, UK, A]
	5210012000	PCB [GE]
F601	▲ 5307004100	Fuse 2A 25V [U, C]
F601	▲ 5041140000	Fuse T1A 250V [E, UK, A]
F601	▲ 5041114000	Fuse 2A 250V [GE]
F602	▲ 5307004300	Fuse 3A 250V [U, C]
F602	▲ 5142190000	Fuse T2.5A 250V [E, UK, A]
F602	▲ 5142211000	Fuse 3A 250V [GE]
F603	▲ 5307004100	Fuse 2A 250V [U, C]
F603	▲ 5142188000	Fuse T1.6A 250V [E, UK, A]
F603	▲ 5041114000	Fuse 2A 250V [GE]
F604, F605	▲ 5307003600	Fuse 1A 250V [U, C]
F604, F605	▲ 5041140000	Fuse T1A 250V [E, UK, A]
F604, F605	▲ 5041101000	Fuse 1A 250V [GE]
	5041237000	Holder, Fuse (10 used) [U, C]
	5142087000	Holder, Fuse (10 used) [E, UK, A]
	5041237000	Holder, Fuse (10 used) [GE]

SPEED SW PCB ASSY (PC Board omitted)

REF. NO.	PARTS NO.	DESCRIPTION
	5200012200	PCB Assy
	5210012200	PCB
S702	5134090000	Switch, Push; 2-gang

VOLUME PCB ASSY (PC Board omitted)

REF. NO.	PARTS NO.	DESCRIPTION
	5200012300	PCB Assy
	5210012300	PCB
S706	5150239000	Var. Res. w/Switch 5kΩ(B)

CONNECTOR PCB ASSY (PC Board omitted)

REF. NO.	PARTS NO.	DESCRIPTION
	5200012100	PCB Assy
	5210012100	PCB-110
J901	5334010100	Connector Socket, 12P
	5554099100	Bracket, Connector

[U]: U.S.A.
[A]: AUSTRALIA

[C]: CANADA
[E]: EUROPE

[GE]: GENERAL EXPORT
[UK]: U.K.











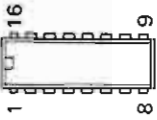
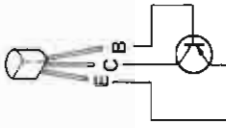
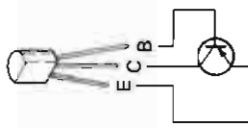

OPERATION SW PCB ASSY (PC Board omitted)

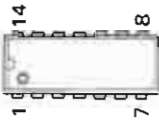
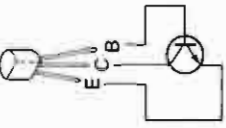
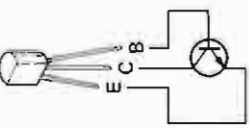
REF. NO.	PARTS NO.	DESCRIPTION
	5200011800	PCB Assy
	5210011800	PCB
D801	5143140000	LED, SLB-26UR1 Red
D802	5143139000	LED, SLB-26GG1 Green
S801~S806	5138011000	Switch, Tact AKC-8C

LED PCB ASSY (PC Board omitted)

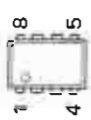
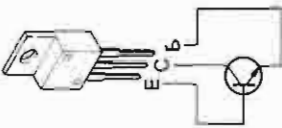
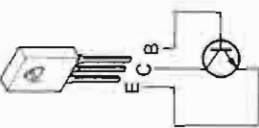
REF. NO.	PARTS NO.	DESCRIPTION
	5200011600	PCB Assy
	5210011600	PCB
DIODES		
D481~D484	5225005400	LED, SLP-135B
RESISTORS		
R481~R484	5225005400	2.7kΩ 5% ¼W

TABLE OF SEMICONDUCTORS

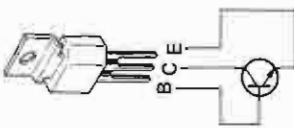
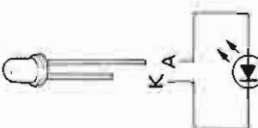
<p>M54410P (TOP VIEW)</p> 	<p>2SA721T 2SA733P 2SA826LNS 2SA984KE</p> 	<p>2SA934Q</p> 	<p>(DIODE)</p>  <p>1S2076FA</p>  <p>BLACK RED</p>  <p>ERB12-02G1</p>
<p>HD7400P (TOP VIEW)</p> 	<p>2SC1815GR 2SC2240BL 2SC2274KE 2SC536F</p> 	<p>2SC2060Q</p> 	<p>1SR34-200VL</p>  <p>DSA26C</p>  <p>W03C</p>  <p>1N60</p> 
<p>JRC4558DD JRC4558DF μPC393C (TOP VIEW)</p> 	<p>2SD313E</p> 	<p>2SD794Q</p> 	<p>(ZENER DIODE)</p>  <p>EQA01-06R</p>  <p>WZ-061</p> 
<p>μPC78M05H</p>  <p>1: OUT 2: GND 3: IN</p>	<p>2SC1226AR</p> 	<p>SLP-135B</p> 	

TEAC[®]
Toscom Series

TEAC CORPORATION

TEAC CORPORATION OF AMERICA

TEAC AUSTRALIA PTY., LTD.

3-7-3 NAKA-CHO MUSASHINO TOKYO PHONE (0422) 53-1111

7733 TELEGRAPH ROAD MONTEBELLO CALIFORNIA 90640 PHONE (213) 726-0303

165-167 GLADSTONE STREET SOUTH MELBOURNE VICTORIA 3205 PHONE 699-6000

PRINTED IN JAPAN 1180 SYU 1 6 D-3562A